



EN

EUROPEAN QUALIFYING EXAMINATION 2026

PAPER B

This paper comprises:

- | | |
|----------------------------------|-----------------|
| * Description of the application | 2026/B/EN/1-4 |
| * Claims of the application | 2026/B/EN/5 |
| * Drawings of the application | 2026/B/EN/6 |
| * Document D1 | 2026/B/EN/7-8 |
| * Document D2 | 2026/B/EN/9-10 |
| * Document D3 | 2026/B/EN/11-13 |
| * Communication | 2026/B/EN/14 |
| * Client's letter | 2026/B/EN/15 |
| * Amended Claims | 2026/B/EN/16 |

Description of the application

[001] The present invention relates to a drip tray for collecting liquid underneath a kitchen appliance. The invention also relates to a combination of the drip tray with a skirting board.

5

[002] Water damage in kitchens due to condensation or leakage from appliances such as refrigerators and dishwashers is an increasing problem, especially in the Nordic countries where houses are well insulated and wooden floors are popular. Even small amounts of liquid on the floorboards will cause water damage that costs homeowners and insurance companies large amounts of money every year.

10

[003] To solve this problem, a drip tray is typically placed underneath the kitchen appliance to collect water. The drip tray has a rectangular base that fits the dimensions of the kitchen appliance. The drip tray also comprises walls that extend along the front, sides and back of the base to form a receptacle that retains water.

15

[004] When moisture condensates on the kitchen appliance and drips down, it drips into the drip tray, not onto the floor. This prevents damage to the floor.

20

[005] However, when a leakage occurs in a kitchen appliance such as a dishwasher, a large quantity of water is released, and it is crucial that the homeowner can act immediately to turn off the water supply and limit the damage. For the homeowner to be able to act, they must be able to see the leaking water on the kitchen floor in front of the drip tray. One problem with prior art drip trays is that a large quantity of water can flow over the sides and the back of the drip tray as well as the front and remain undetected underneath cupboards and inside kitchen walls. In particular where a skirting board is used in connection with the kitchen appliance, the skirting board can trap the water and prevent the leak from being detected. A skirting board is a piece of wood that is attached to the base of a wall to protect the wall where it meets the floor. Skirting boards are also commonly arranged along the floor at the lower portion of kitchen appliances.

25

30

[006] There are some drip trays provided with electronic leak detection, but these are often expensive to manufacture and their alarms stop functioning when the battery runs out. With leakages more likely towards the end of the lifetime of a dishwasher or refrigerator (a lifetime of typically at least ten years), there is a risk that a drip tray with an electronic alarm already stops functioning before a leakage occurs.

[007] The purpose of the present invention is to provide a drip tray which retains condensation and ensures that leakage is detected immediately.

[008] This is achieved by the provision of a drip tray with a front wall that is lower than the sidewalls and the rear wall, to ensure that water from a leakage flows over the front of the drip tray onto the floor forming a puddle that is visible.

[009] When the drip tray is placed on the floor and is combined with a skirting board, floor supports elevate the skirting board to a height above the front wall of the drip tray. This ensures that water is not trapped behind the skirting board.

[010] Brief description of the drawings

Fig. 1 is a schematic drawing of the drip tray according to claim 1,

Fig. 2 is a schematic cross-sectional drawing of the drip tray from the side, and Fig. 3 is a schematic drawing of the drip tray combined with the skirting board.

[011] In Fig. 1, the drip tray 1 comprises a rectangular base 2 with sidewalls 3, a rear wall 4 and a front wall 5 that form a continuous wall around the base 2. The front wall 5 is lower than the sidewalls 3 and the rear wall 4 so that water from a leak (leakage) is hindered from flowing over the sides and the back of the drip tray 1 and being hidden from view.

[012] The front wall 5 has a height A of 10-20 mm whereas the sidewalls 3 and the rear wall 4 have a height B of at least 40 mm. The front wall 5 also comprises a recess 6 that forms a central outlet for water, ensuring that the leakage is directed onto the floor in front of the drip tray 1. The recess 6 reaches down to a height C that is smaller than the height A of the front wall 5. The drip tray 1 also comprises receivers 7 in which a skirting board 10 can be mounted.

35

[013] It is essential to reliably differentiate between a leakage that must be detected and condensation on the drip tray 1 that can be left to dry without requiring action from the homeowner. This is achieved using the recess 6, as water overflowing via the recess 6 will be directed onto the floor for detection while smaller volumes caused by condensation will remain in the drip tray 1.

[014] Fig. 2 shows the drip tray 1 from the side with a dashed line indicating the position of the recess 6 in the front wall 5. Water at levels below this line is considered to be condensation that should be kept in the drip tray 1. Water above this line is considered to be leakage that must be guided onto the floor for detection.

[015] Also shown in Fig. 2 is an adhesive strip 8 that may optionally be provided on the base 2 to attach the drip tray 1 to the floor. One advantage of the adhesive strip 8 is that it holds the drip tray 1 securely to the floor while the kitchen appliance is installed. It also lowers the risk of water being sucked underneath the drip tray 1 by capillary force.

[016] Fig. 3 shows the drip tray 1 combined with the skirting board 10. The skirting board 10 prevents dust and dirt from entering the space underneath the kitchen appliance and is also aesthetically pleasing as it hides the legs of the appliance. The skirting board 10 is mounted on floor supports 11 that in turn fit into the receivers 7 that extend from the sidewalls 3 of the drip tray 1. In this way, the skirting board 10 is reliably held in place on the drip tray 1. Conveniently, the receivers 7 form a snap connection with the floor supports 11: mounting the skirting board 10 on the drip tray 1 is done by snapping the floor supports 11 into the receivers 7.

[017] The floor supports 11 have a height D that is larger than the height A of the front wall 5 of the drip tray 1 so that a gap is formed between the drip tray 1 and the skirting board 10. This means that water from a leakage can flow onto the floor for detection, not only when water from a smaller leakage is discharged at the recess 6 but also when a very large leakage occurs so that water flows over the entire front wall 5.

[018] The recess 6 of the embodiment of Fig. 3 is V-shaped but may in other embodiments have other shapes, such as a U-shape (see Fig. 1). In principle, the recess 6 of the drip tray 1 can have any shape.

5 [019] The drip tray 1 of Fig. 1-3 is made from polypropylene (PP). This polyolefin is the preferred material, but any other suitable polyolefin can be used. Some non-polyolefin polymers can also be suitable, for example polyethylene terephthalate (PET), polycarbonate (PC), polyvinylchloride (PVC), acrylonitrile-butadiene-styrene (ABS) copolymer, melamine, poly(methylmethacrylate) (PMMA), or mixtures thereof. In some
10 embodiments, the drip tray 1 can instead be made from other materials, such as aluminium or stainless steel.

[020] The polymer can comprise one or more additives, such as stabilisers and biocides, to prevent mould growing on the surface of the drip tray. Known anti-mould additives
15 include triclosan, compounds of the isothiazolinone family, nisin, and inorganic compounds based on silver, copper or zinc. The preferred anti-mould additive is triclosan.

[021] The drip tray 1 of the invention is cheap to manufacture and ensures reliable detection of leakage during the lifetime of the kitchen appliance. Even though a
20 dishwasher or refrigerator may last for ten years, the drip tray 1 does not need to be replaced. Also, as small quantities of water resulting from condensation are collected without the homeowner being alerted, the risk of false alarms is eliminated.

[022] The main embodiment of Fig. 1 shows a height A of the front wall 5 of 10-20 mm.
25 This height can be changed without impacting the ability of the invention to collect condensation while reliably indicating leakage: in some embodiments, other heights can be used, as long as the front wall 5 is lower than the sidewalls 3 and the rear wall 4.

Claims of the application

- 5 1. Drip tray (1) for collecting liquid underneath a kitchen appliance, the drip tray (1) comprising a rectangular base (2) delimited by sidewalls (3), a rear wall (4), and a front wall (5), said walls forming a continuous wall around the base (2),
characterised by the front wall (5) being lower than the sidewalls (3) and the rear wall (4).
- 10 2. Drip tray (1) according to claim 1, wherein the front wall (5) has a height (A) of 10-20 mm.
- 15 3. Drip tray (1) according to claim 2, wherein the front wall (5) comprises a recess (6) forming an outlet, and wherein the recess (6) is V-shaped.
- 20 4. Drip tray (1) according to claim 1, wherein the drip tray (1) comprises a polyolefin.
- 25 5. Drip tray (1) according to claim 1, wherein the drip tray (1) is connected to a skirting board (10) by a snap connection formed by floor supports (11) of the skirting board (10) fitting into receivers (7) extending from the base (2).
- 30 6. Combination of skirting board (10) and drip tray (1), wherein the drip tray (1) comprises a rectangular base (2) delimited by sidewalls (3), a rear wall (4), and a front wall (5), said walls forming a continuous wall around the base (2), and wherein the skirting board (10) comprises floor supports (11) for elevating the skirting board (10) from the floor, **characterised by** the floor supports (11) having a height (D) that is larger than the height (A) of the front wall (5) of the drip tray (1).
7. Combination of skirting board (10) and drip tray (1) according to claim 6, wherein the drip tray (1) comprises an adhesive strip (8) for mounting the drip tray (1) on a floor.

Drawings of the application

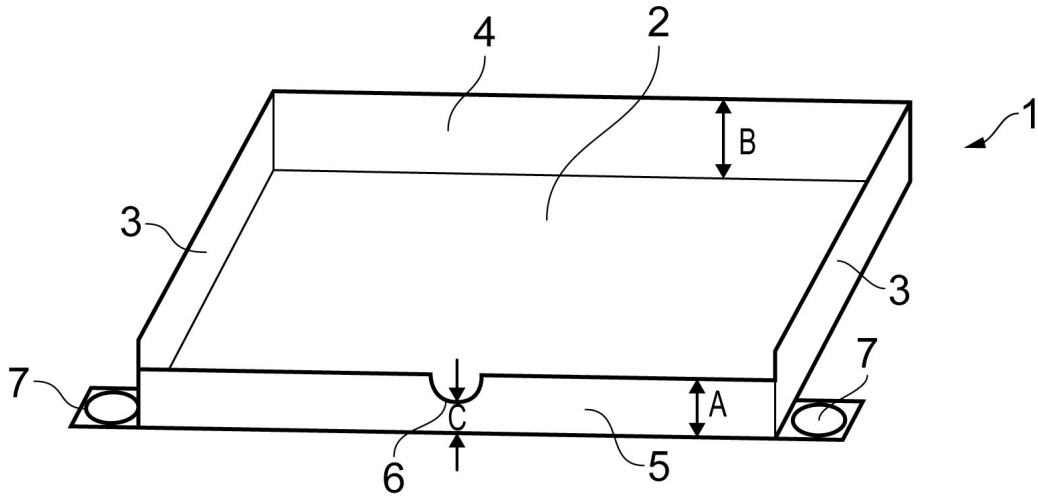

FIG . 1

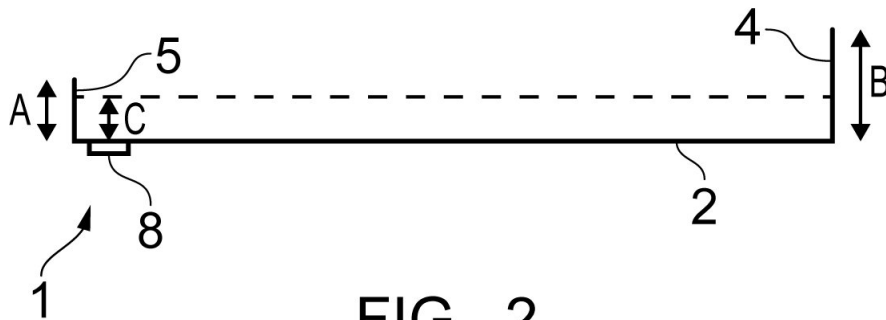

FIG . 2

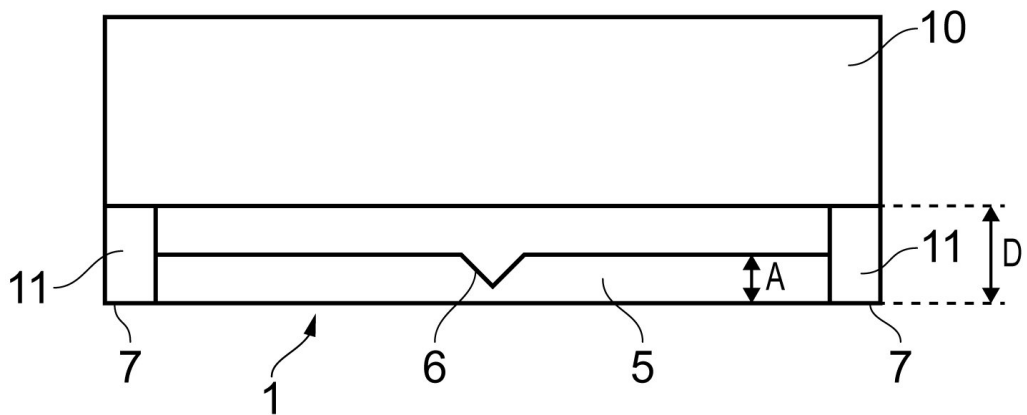

FIG. 3

D1: Drip tray

5 [001] Drip trays are used to prevent water damage to the floor underneath kitchen appliances. The appliance, typically a refrigerator, is equipped with wheels so that it can be rolled into place on the drip tray.

10 [002] A common problem is that the wheels may damage the front wall of the drip tray when rolled over the front wall due to the weight of the appliance. If the front wall is damaged, water dripping from the kitchen appliance during use (typically as a result of condensation) can escape from the drip tray where the damage has occurred and can cause water damage to the floor. In particular, water may collect underneath the drip tray due to capillary forces and remain undetected until the kitchen appliance reaches the end of its lifetime and is replaced.

15 [003] To resolve this problem, the invention comprises a reinforced front wall with a rounded top that is able to withstand the weight of the appliance without deforming or breaking. As well as being reinforced, the front wall is also lower than the corresponding sidewalls and rear wall to ensure that the wheels of the appliance can easily roll over the front wall.

20 [004] Another problem with drip trays is that they can be moved or misaligned by the wheels of the kitchen appliance. To resolve this, an adhesive strip can be provided to fix the drip tray to the floor before the kitchen appliance is rolled into place.

25 [005] The drip tray comprises a polymer material. We have found that the polyolefins polyethylene and polypropylene are particularly suitable for the reinforced front wall. In some embodiments, the front wall is reinforced by using a sturdier material than the other parts of the drip tray. In other embodiments it is of the same material but thicker.

30 [006] If the kitchen appliance is a dishwasher, the drip tray can be combined with a skirting board to achieve an aesthetically pleasing and uniform appearance with the kitchen cupboards. For this purpose, the skirting board should fit on the floor in front of the front wall so that the drip tray is hidden from view.

[007] Fig. 1 shows the drip tray 1 with a base 2 and walls 3, and with the front wall 4 lowered. Fig. 2 shows the drip tray 1 in a cross-sectional view from above with the front wall 4 reinforced by being thicker than the other walls 3. Fig. 3 shows the drip tray 1 in a cross-sectional view from the side during installation of a kitchen appliance 5. In particular, 5 Fig. 3 shows that the front wall 4 remains undamaged despite a wheel 6 of the kitchen appliance 5 having rolled over it.

Drawings D1:

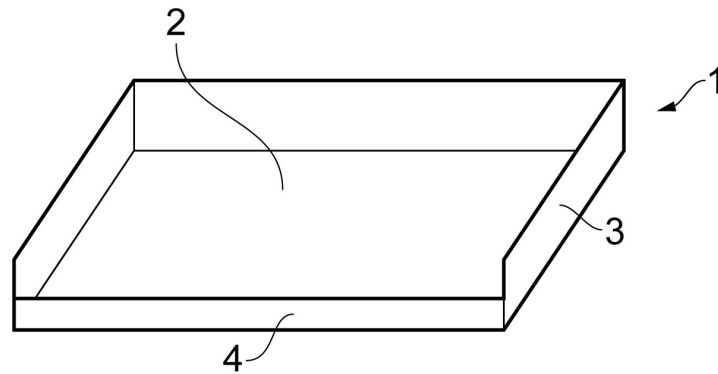

FIG. 1

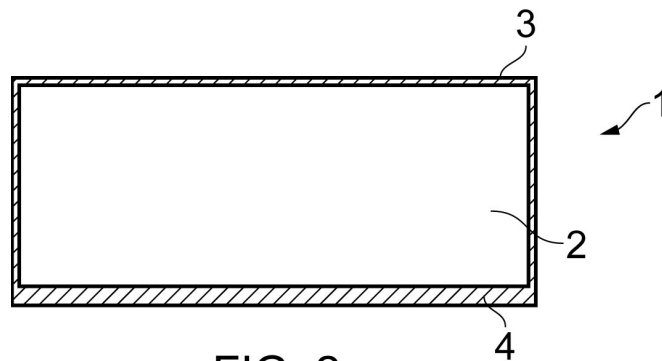

FIG. 2

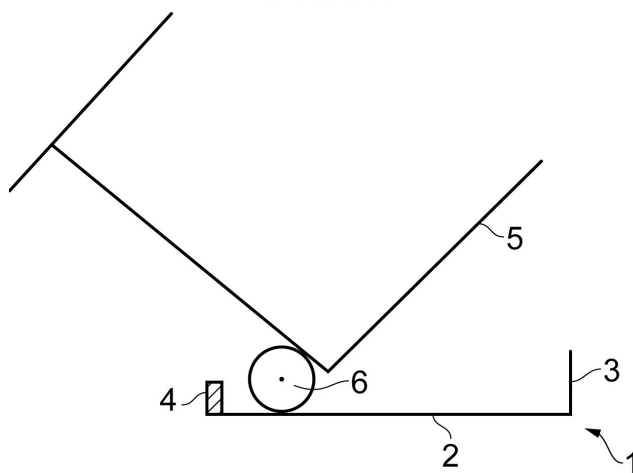

FIG. 3

D2: Water retainer

5 [001] Water damage due to leakages from kitchen appliances such as refrigerators is an increasing problem with a high cost to homeowners and insurance companies. To alleviate this problem, we present a water retainer that can be arranged underneath a refrigerator or freezer to capture any leakage.

10 [002] The water retainer has a rectangular base with a continuous wall extending around the edges of the base. The wall can be 5-10 cm high to ensure that a large volume of water can be held in the retainer without leaking onto the floor. It is advantageous to provide such high walls since this increases the volume that the water retainer is able to hold.

15 [003] After the homeowner has been alerted to the malfunction of the refrigerator or freezer and the water supply has been shut off to prevent further leaks, a hose can be inserted between the kitchen appliance and the water retainer to allow the emptying of the water retainer by pumping or any other suitable way. To allow for the insertion of the hose, the continuous wall is lower on the front side of the water retainer.

20 [004] To facilitate installation, sealable openings are provided in the sidewalls for insertion of handles to lift the water retainer into place. Before using the water retainer and to prevent water exiting the water retainer, it is important to cover these openings with plugs, flaps or other closures that provide a watertight seal.

25 [005] There can also be at least one adhesive strip provided to fix the water retainer to the floor. This ensures that the water retainer remains in place while the refrigerator is installed.

[006] If there is a skirting board installed in combination with the kitchen appliance, it will need to be removed before water is emptied from the water retainer. The skirting board could also be mounted directly on the water retainer, for instance through snap connections that connect the floor supports of the skirting board to receivers on the water
5 retainer.

[007] Fig. 1 shows the water retainer 1 with a base 2 and continuous wall 3 having a lower front side 4 and sealable openings 5.

10 **Drawing D2:**

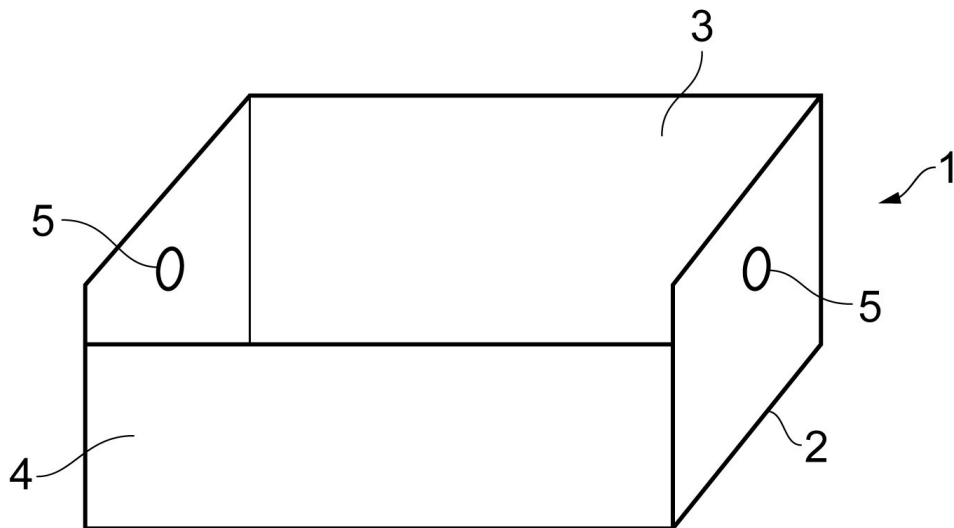

FIG. 1

D3: Dishwasher drip tray

[001] The present invention concerns a drip tray for detecting a leakage underneath a kitchen appliance. The drip tray comprises a rectangular base with a continuous sidewall that delimits the base, and is equipped with an alarm that is triggered when water fills the base.

[002] Fig. 1 discloses the drip tray 1 comprising the base 2 and the continuous sidewall 3. A front section 4 of the sidewall 3 houses the alarm 5 and a battery 6. There are also wires in the form of a first wire section 71 and a second wire section 72 that are arranged on the base and are connected to the alarm 5 and the battery 6. The wire sections 71 and 72 are arranged on the base 2 with a gap 9 between them forming an open circuit 8. This is shown in Fig. 2 showing the drip tray 1 from above, and in Fig. 3 showing a circuit diagram that comprises only the components of the circuit 8 and not the drip tray 1 as such.

[003] In order to use the drip tray 1, it is placed on the floor and optionally also attached to the floor by means of an adhesive strip (not shown). A kitchen appliance, such as a dishwasher, is then placed on top of the drip tray 1. Optionally, a skirting board is added to hide the drip tray and the legs of the appliance from view.

[004] As long as the drip tray 1 is dry, the alarm remains inactive. However, when a leakage occurs and water collects on the drip tray 1, the water fills the gap 9, enabling electrical current to flow from the first wire section 71 to the second wire section 72. This closes the circuit 8 and activates the alarm. In a low-tech embodiment, the alarm can be an acoustic signal that alerts the homeowner to the leakage. In a more advanced embodiment, the alarm can additionally be connected to a home alarm system or a mobile phone. Optionally, the drip tray 1 is also connected to a switch that shuts off the water supply to the kitchen when the alarm is activated. In the more advanced embodiment, it is also possible to monitor the status of the battery to ensure that it has not run out. However, even the low-tech embodiment is also very reliable since the battery 6 used in the drip tray 1 has a lifetime of at least three to five years.

[005] A particular advantage of the drip tray is that even a small leakage can be detected immediately to prevent the floorboards from getting wet. Also, in an improvement to prior art drip trays, the front section 4 of the sidewall is lower in order to reduce the risk of the legs of the appliance hitting the front section 4 as the appliance is lifted into place. The height of the front section 4 should be 30 mm or less. In earlier drip trays it was a common problem that damage to the front section would also damage the battery and the alarm or even break the wire. If the wire is broken, the drip tray 1 is not able to alert the homeowner to the leakage since the circuit 8 cannot be closed to activate the alarm.

10 [006] The drip tray 1 can also be combined with a skirting board if desired. If a skirting board is used, it is advantageous to cut out a section of the skirting board to make the front section 4 of the drip tray 1 visible. Alternatively, the skirting board can be arranged on floor supports that raise the skirting board from the floor and expose the entire front section 4. This makes it easier to assess the damage when the alarm is activated, as the homeowner can then inspect the drip tray 1 without having to remove the skirting board, for example by shining a flashlight into the space between the front section 4 and the skirting board. To achieve this, the floor supports should have a height that is greater than the height of the front section 4.

20 [007] Suitable materials for the drip tray 1 include any kind of polymer, and in particular the polyolefins polyethylene and polypropylene. These materials may comprise additives to prevent the growth of bacteria or fungi, such as mould, on the surface of the drip tray.

Drawings D3:

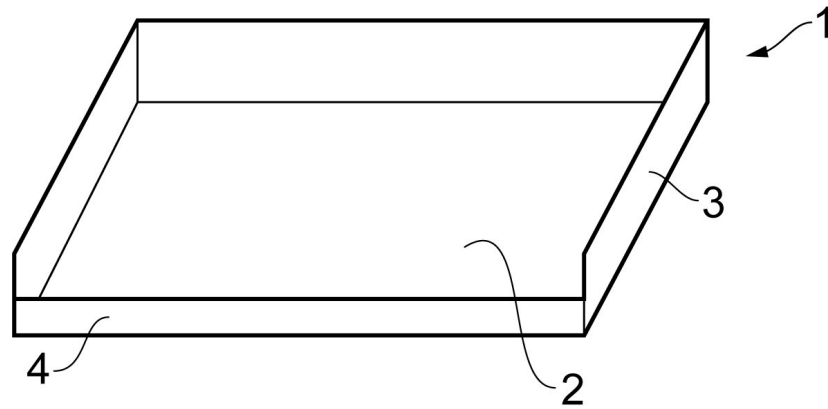

FIG. 1

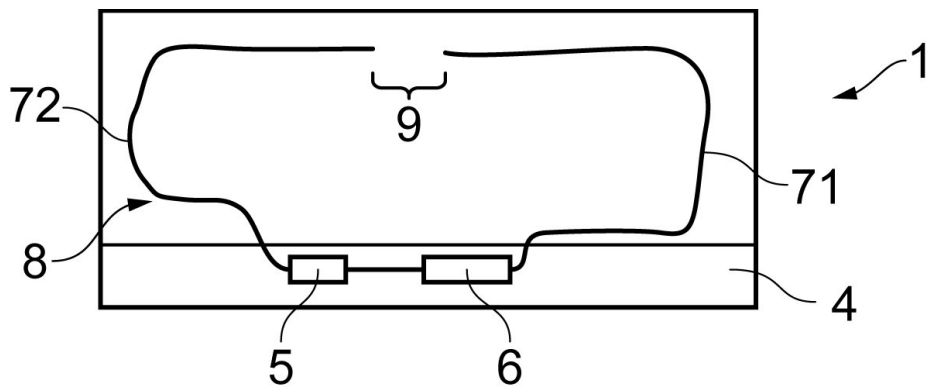

FIG. 2

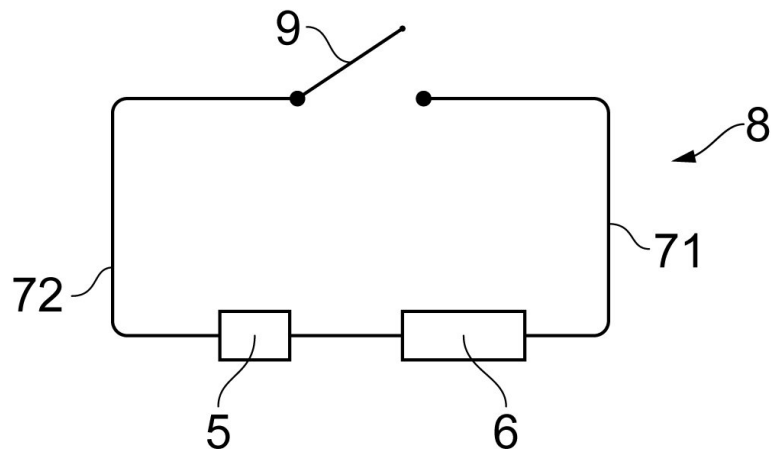

FIG. 3

Communication pursuant to Article 94(3) EPC

1. The examination is based on the application documents as originally filed. Attached documents D1, D2 and D3 are prior art according to Article 54(2) EPC.

5

2. Claims 1-5 directed to a drip tray and claims 6-7 directed to the combination of a skirting board and a drip tray are not linked so as to form a single general inventive concept, because the common matter that could link different solutions is known from document D1 or D3. The requirements of Article 82 EPC are therefore not met. However, a search has been carried out for the subject-matter of claims 1 to 7 in its entirety.

10

3. D1 to D3 each disclose the features of claim 1, showing a drip tray with a base delimited by sidewalls where the front wall is lower than the sidewalls and rear wall. Claim 1 is therefore not novel in the sense of Article 54(1) and (2) EPC.

15

3.1 Furthermore, document D3 discloses all features of claim 6, combining the drip tray with a skirting board arranged on floor supports with a height that is greater than a height of the front wall of the drip tray. Claim 6 therefore also lacks novelty.

20

4. Claim 5 does not fulfil the requirements of Article 84 EPC, since it attempts to define the subject-matter in relation to a separate entity not forming part of the claim. This renders the claim unclear.

25

5. Dependent claims 2-5 and 7 do not appear to contain any feature that could contribute to an inventive concept and lack inventive step under Article 56 EPC.

Client's letter

Dear Ms Hart,

5 Please see the attached set of claims to overcome the objections raised in the communication pursuant to Article 94(3).

10 We have added as a feature of the drip tray the ability to retain small quantities of water but not large quantities. This is an important advantage of our invention as it enables retention of condensation but ensures that water from a leakage is guided onto the floor for detection.

15 The objection to claim 6 has been resolved by making this claim dependent on claim 5, as this is where the skirting board is first mentioned in the claims set.

20 When developing the product, we realised that the polyolefins polyethylene (PE) and polypropylene (PP), both comprising the anti-mould additive triclosan, are the best of the polymers we tested. We have therefore added this to a dependent claim. In our opinion, this is allowable since the description mentions polyolefins in general and it is well known that PE and PP are the most common polymers for trays.

25 Also, testing has shown that a V-shaped recess achieves the best results but that other shapes also work reasonably well. We have deleted the V-shape references from claim 3 because we want to make sure that the claim set is not limited to this shape for the recess.

30 We noted that the communication pointed out a problem with claim 5, but we are not sure how it can be resolved. The skirting board combined with the drip tray is an important product so please ensure that we achieve protection for all claims mentioning the skirting board as well as for the drip tray on its own.

35 Please make any amendments to our proposed claim set that you consider necessary to meet the requirements of the EPC, without adding further dependent claims.

Kind regards,

35 M.A. Jansson

Client's amended claims

1. Drip tray (1) for collecting liquid underneath a kitchen appliance, the drip tray (1) comprising a rectangular base (2) delimited by sidewalls (3), a rear wall (4) and a front wall (5), said walls forming a continuous wall around the base (2),
5 **characterised by** the front wall (5) being lower than the sidewalls (3) and the rear wall (4) so that condensation is collected on the drip tray but a leakage is not.
2. Drip tray (1) according to claim 1, wherein the front wall (5) has a height (A) of 10-
10 20 mm.
3. Drip tray (1) according to claim 2, wherein the front wall (5) comprises a recess (6) forming an outlet, ~~and wherein the recess (6) is V-shaped.~~
- 15 4. Drip tray (1) according to claim 1, wherein the drip tray (1) comprises a ~~polyolefin~~ polyethylene or polypropylene and also comprises triclosan.
5. Drip tray (1) according to claim 1, wherein the drip tray (1) is connected to a skirting board (10) by a snap connection formed by floor supports (11) of the skirting board
20 (10) fitting into receivers (7) extending from the base (2).
6. ~~Combination of skirting board and d~~Drip tray (1) according to claim 5, wherein the drip tray (1) comprises a rectangular base (2) delimited by sidewalls (3), a rear wall (4) and a front wall (5), said walls forming a continuous wall around the base (2),
25 and wherein the skirting board (10) comprises floor supports (11) for elevating the skirting board (10) from the floor, **characterised by** wherein the floor supports (11) haveing a height (D) that is greater than a height (A) of the front wall (5) of the drip tray (1).
- 30 7. ~~Combination of skirting board and d~~Drip tray according to claim 6, wherein the drip tray (1) comprises an adhesive strip (8) for mounting the drip tray (1) on a floor.