

EUROPEAN QUALIFYING EXAMINATION 2024

Paper C

Part 1

This paper contains:

- | | |
|--------------------------|------------------|
| * Letter of the opponent | 2024/C1/EN/1-2 |
| * Annex 1 | 2024/C1/EN/3-13 |
| * Annex 2 | 2024/C1/EN/14-18 |
| * Annex 3 | 2024/C1/EN/19-23 |
| * Annex 4 | 2024/C1/EN/24-27 |
| * Annex 5 | 2024/C1/EN/28-30 |

Encrypted email from:

Mr. Stael Kaolin
Paddle Science Laboratories
481 8th Avenue
New York 10001-1809
USA

To: Ms. Molly Dorsett Pauley
European Patent Attorney
Todiet Kwiscus LLC
Upper Coxley
Wells BA5 1QS
Great Britain

Sent: Thursday, 14 March 2024 08:30

Subject: Opposition against EP3831740B1

Dear Ms. Pauley,

Please file an opposition at the European Patent Office against European patent EP3831740B1 (Annex 1) on behalf of my company. I trust that the attached Annexes 2 to 5 will be of use to you in this regard.

Unfortunately, all of our IT systems except for the mail server broke down this morning. I am sending you what I currently have of Annex 1 (missing parts indicated). The remaining annexes attached to this email are complete.

I have also started to consult the file history of Annex 1. This is what I have found out up to now:

- (i) The priority applications NO20200113 and NO20200355 contain the following parts of Annex 1: paragraphs 1 to 13, figures 1 to 4, claims 1 and 2.
- (ii) Annex 1 was granted for European patent application EP20453334.5, which was filed containing the following parts of Annex 1: paragraphs 1 to 20, figures 1 to 4, claims 2 and 3. Claim 1 of Annex 1 was amended during examination. The following text was added to claim 1 as originally filed:

the magnetic material comprising amorphous CoFeNi at 10 - 30% and nanocrystalline FeCuSiB at 20 - 40% by weight of the magnetic material.

Claim 1 is of particular concern to my company. In some of the devices which my company wants to commercialize the magnetic material of the first layer comprises CoFeNi at about 15% and FeCuSiB at about 35% by weight of the magnetic material. We have heard that all potentially relevant objections should be raised within the time limit for filing an opposition. Please make sure that the most probable fallback positions for claim 1 are covered in your notice of opposition.

Regarding Annex 2, I discovered the following by way of online file inspection. Annex 2 claims the priority of European patent application EP19732000.1, which was filed on 18 January 2019 and claims no priority. Right now I do not have a copy of EP19732000.1 but I checked previously and the description, claims and figures are all identical to those of Annex 2. EP19732000.1 was published as EP3383351A1 on 23 July 2020.

Kind regards,

Stael Kaolin

Annexes

Annex 1 (A1) EP 3 831 740 B1

Annex 2 (A2) EP 3 781 517 A1

Annex 3 (A3) US 10545718 B1

Annex 4 (A4) EP 3 513 705 A1

Annex 5 (A5) Advertising brochure

(19)



Europäisches Patentamt
European Patent Office
Office européen des brevets

(11) EP 3 831 740 B1

(12)

EUROPEAN PATENT SPECIFICATION

(45) Date of publication and mention
of the grant of the patent:
14 June 2023 Bulletin 2023/24

(51) Int. Cl. : **H02J50/12,**
H01F1/15333,
H04B5/0043,
B60L53/124,
B60L53/64

(21) Application number: **20453334.5**

(22) Date of filing: **25 July 2020**

(54) **Wireless charging pad**
Kabellose Ladeplatte
Plaque de charge sans fil

(84) Designated Contracting States:
AL AT BE BG CH CY CZ DE DK EE
ES FI FR GB GR HR HU IE IS IT LI
LT LU LV MC ME MK MT NL NO PL
PT RO RS SE SI SK SM TR

(30) Priority:
14 March 2020 NO20200113
25 May 2020 NO20200355

(43) Date of publication of application:
4 August 2021 Bulletin 2021/31

(71) Applicant:
Mute&Mancer Corp
Winterstr. 23
1984 Rioneuro (LT)

(72) Inventor:
C. Estsec, Bolt O. Nipswich

(73) Proprietor:
Mute&Mancer Corp

(74) Representative:
Slart Bartifast
29 Arlington Avenue
London N1 7BE (GB)

Note: Within nine months of the publication of the mention of the grant of the European patent in the European Patent Bulletin, any person may give notice to the European Patent Office of opposition to that patent, in accordance with the Implementing Regulations. Notice of opposition shall not be deemed to have been filed until the opposition fee has been paid (Art. 99(1) European Patent Convention).

[1] This invention concerns charging a battery of a battery-powered car. The conventional way to charge such a battery is using plug-socket systems, which require plugging a cable into a socket of the car and into a socket of a charging terminal providing the electric energy needed.

[2] Plug-socket systems have several safety features. For instance, protective reinforcements of the cable ensure mechanical resistance. In addition, switches in the charging terminal make it possible to keep the cable free from electrical energy unless the battery is being charged. However, inserting the plug into the socket requires manual user interaction, which comes with risks.

[3] This disadvantage can be avoided with wireless charging, which is illustrated in Fig. 1. Energy to charge the battery is transmitted without wires from a ground charging pad 111 to a car charging pad 112 by electromagnetic fields 115.

[4] To compete with plug-socket systems in terms of charging speed and energy efficiency, the charging pads each have to contain a coil for resonant wireless charging. The resulting concept is illustrated in Fig. 2.

[5] A transmitting charging pad 121 and a receiving charging pad 122 are brought close together. Both pads comprise a coil, which is a conductive trace with several concentric windings. Electric energy 123 to be transmitted is sent into coil 124 as an alternating current at a charging frequency. Coil 124 thereby produces an alternating electromagnetic field with field lines 125 which also pass through coil 126.

[6] Each of the coils is a coil for resonant wireless charging. To have this property, a coil has to have a layout such that it is tuned to the charging frequency. The electromagnetic fields passing through both coils thereby establish a resonant link between the charging pads. This allows extracting electric energy 127.

[7] For optimum electromagnetic coupling strength, a charging pad has to be well aligned with its opposite charging pad. Reducing sensitivity to misalignment is difficult with the arrangement shown in Fig. 2.

[8] Fig. 3 and Fig. 4 show aspects of a charging pad according to the invention. As is typical in this technical field, only a few windings are shown; a real device may contain more. The opposite charging pad is not shown in Fig. 3 and Fig. 4.

[9] A charging pad according to an embodiment of the invention comprises a first coil 131 and second coil 132, both for resonant wireless charging, the first coil and the second coil being arranged side by side. This arrangement is more complex than that of a charging pad with a single coil. However, it reduces sensitivity to misalignment and increases electromagnetic coupling strength without requiring a larger charging pad.

[10] The charging pad according to the embodiment of the invention also comprises a first layer 135 made of a magnetic material, the first coil and the second coil having been placed on a first surface of the first layer and the first layer has been treated so that the first coil and the second coil have sunk into the first layer. For instance, the first layer may initially be liquid and solidify after provision of the coils. Although the coils may end up not being completely covered, they effectively become surrounded by the magnetic material.

[11] Magnetic material, i.e. any material having at least some magnetic or magnetisable particles, generally has the beneficial effect of increasing the strength of the electromagnetic coupling to the coil of the opposite charging pad. The magnetic material in the embodiment of the invention is a composite comprising suitable amounts of an alloy of cobalt, iron and nickel (CoFeNi) and an alloy of iron, copper, silicon and boron (FeCuSiB). Such a composite has been found to have superior electromagnetic coupling strength if CoFeNi is amorphous and FeCuSiB is nanocrystalline.

[12] A composite having very good long-term mechanical stability is obtained if nanocrystalline FeCuSiB is 30 - 40% by weight of the material. However, FeCuSiB has a high oxidation susceptibility, which entails the problem of corrosion sensitivity.

[13] For such a composite the use of at least 10% amorphous CoFeNi by weight of the material has the surprising effect of preventing oxidation of FeCuSiB. However, too much CoFeNi worsens the long-term mechanical stability, and therefore the amount of amorphous CoFeNi has to be below 20% by weight of the material for such a composite.

[14] An alternative composite having high thermal tolerance is obtained if the amount of amorphous CoFeNi is more than 20% and less than 30% by weight of the material. In this case it is necessary to include 20 - 30% nanocrystalline FeCuSiB by weight of the material; otherwise the composite is not usable because of insufficient long-term mechanical stability.

[15] In an embodiment of the invention, the magnetic material is magnetisable concrete. This is magnetic material comprising cement and having a density of at least 2000 kg/m³.

[16] The charging pad may comprise a second layer 136 next to the first layer.

[17] Magnetisable concrete is too heavy for a car charging pad but it has the same abrasion resistance and thermal expansion coefficient as standard road surface materials. This is beneficial for installation in public environments where ground charging pads remain permanently in the same place and position.

[18] However, the typical magnetisable concrete does not sufficiently inhibit the leakage of unwanted radiation, and so further improvements are required to ensure compliance with regulatory radiation standards.

[19] The second layer 136 may be made of an electrically conductive material, for instance metal. Within such a second layer neutralising currents, known as eddy currents, are created which locally cancel the unwanted radiation.

[20] Leakage of unwanted radiation is thereby reduced. A combination with other measures to reduce leakage of unwanted radiation may be useful to ensure compliance with regulatory radiation standards.

Further paragraphs only available in part 2

Further paragraphs only available in part 2

Claim 1

Charging pad comprising:

a first coil (131) and a second coil (132), both for resonant wireless charging, the first coil and the second coil being arranged side by side, and

a first layer (135) made of a magnetic material,

wherein the first coil and the second coil have been placed on a first surface of the first layer and the first layer has been treated so that the first coil and the second coil have sunk into the first layer,

the magnetic material comprising amorphous CoFeNi at 10 - 30% and nanocrystalline FeCuSiB at 20 - 40% by weight of the magnetic material.

Claim 2

Charging pad according to claim 1, wherein

the magnetic material comprises amorphous CoFeNi at 20 - 30% and nanocrystalline FeCuSiB at 20 - 30% by weight of the magnetic material.

Claim 3

Charging pad comprising:

a first coil (131) and a second coil (132), both for resonant wireless charging, the first coil and the second coil being arranged side by side, and

a first layer (135) made of magnetisable concrete;

the charging pad further comprising a second layer (136) made of an electrically conductive material and arranged next to the first layer.

Further claims only available in part 2

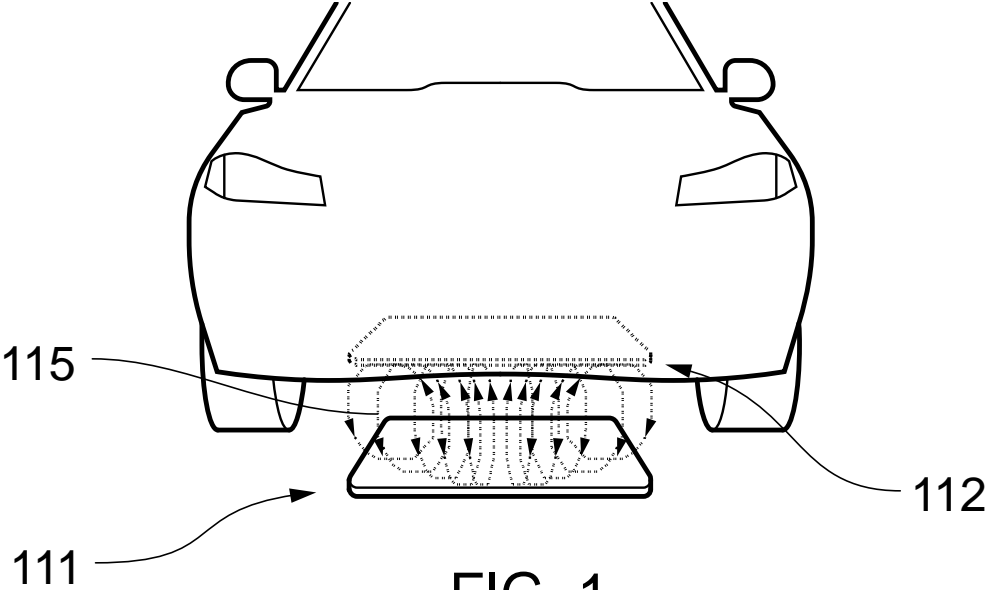

FIG. 1

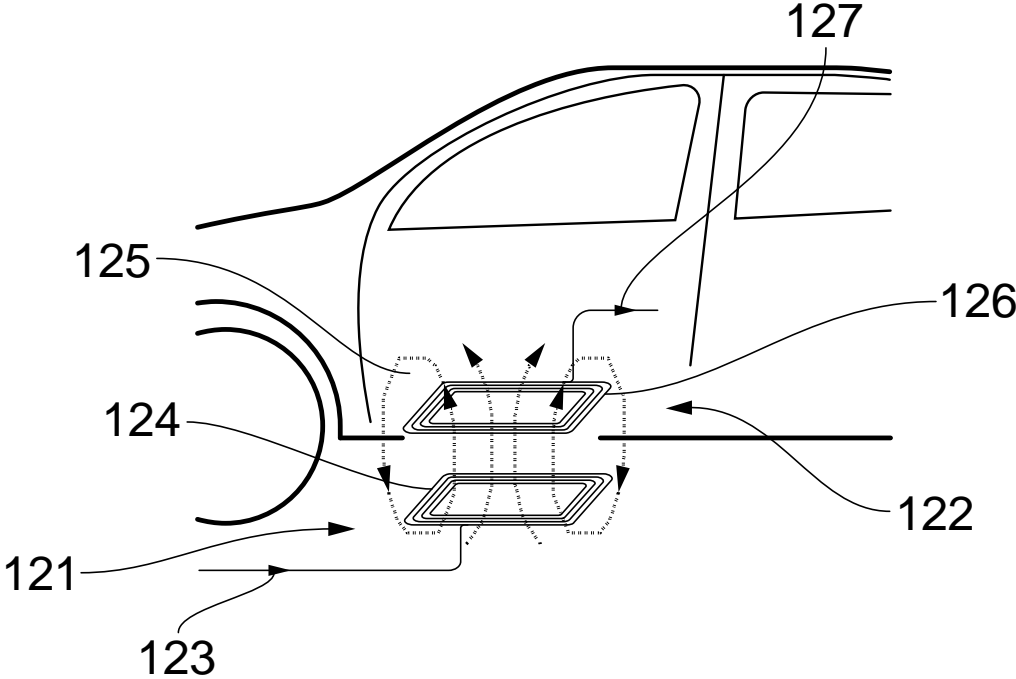

FIG. 2



FIG. 3

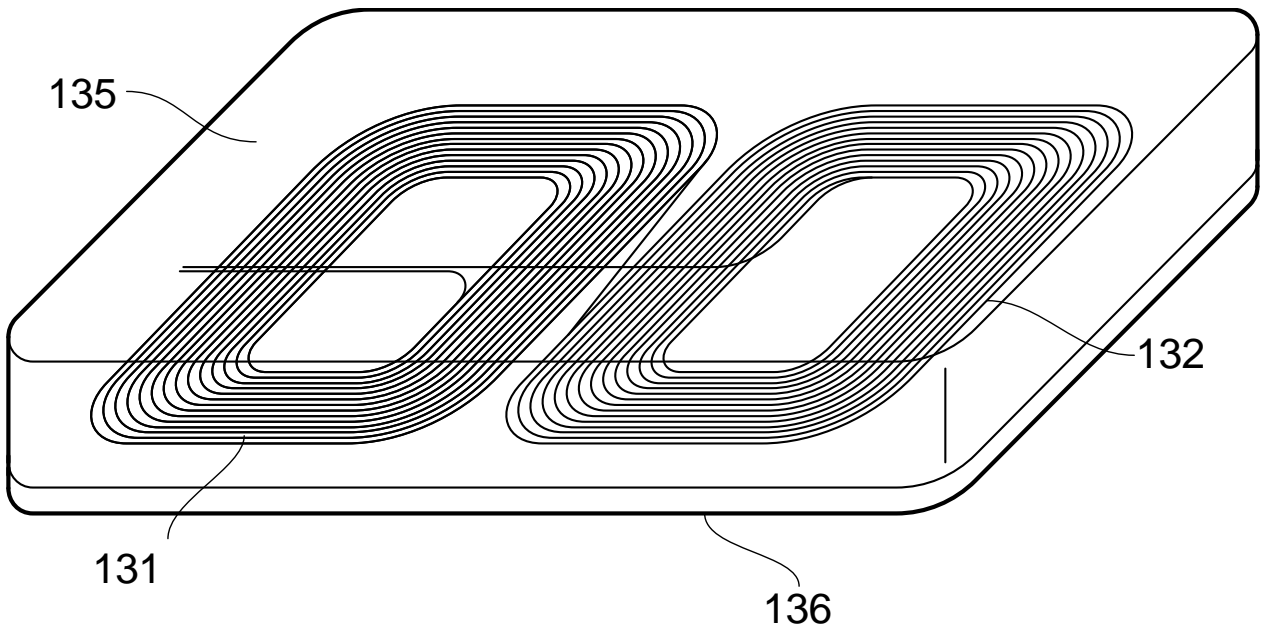

FIG. 4

Further Figures only available in part 2

(19) European Patent Office

(21) Application number:	20173205.0
(11) Publication number:	EP 3 781 517 A1
(45) Date of filing:	6 January 2020
(43) Date of publication:	29 July 2020 / Bulletin 2020/26
(30) Priority:	18 January 2019 EP19732000.1
(51) Int. Cl.:	H01F27/28, H01F1/14766
(71) Applicant:	Mute&Mancer Corp
(72) Inventor:	Puristsaf T. Fastsirup, C. Estsec

(54) Charging pad

[1] Wireless charging is increasingly used to provide energy for the battery in a battery-powered vehicle. A vehicle is a device for carrying objects or individuals, such as a car.

[2] A charging pad according to an embodiment of the invention comprises a first coil 131 and second coil 132, both for resonant wireless charging, the first and the second coil being arranged side by side.

[3] The charging pad according to the embodiment of the invention also comprises a first layer 135 made of a magnetic material, the first coil and the second coil having been placed on a first surface of the first layer and the first layer has been treated so that the first coil and the second coil have sunk into the first layer. Although the coils may end up not being completely covered, they effectively become surrounded by the magnetic material.

[4] The magnetic material in the embodiment of the invention is a composite comprising suitable amounts of an alloy of cobalt, iron and nickel (CoFeNi) and an alloy of iron, copper, silicon and boron (FeCuSiB). Preferably, the magnetic material comprises grains of amorphous CoFeNi at 20 - 30% and nanocrystalline FeCuSiB at 20 - 30% by weight of the magnetic material.

[5] Nanocrystalline alloys were discovered in 1993 and are characterised by having crystal cells smaller than 1 micrometre. It is generally known that amorphous alloys are alloys without crystal cells. Grains, sometimes called particles, are typically larger than 1 micrometre.

[6] In an aspect of the invention, the magnetic material has a density of at least 2000 kg/m³ and comprises cement and magnetic particles.

[7] The charging pad may comprise a second layer 136 next to the first layer.

[8] However, typical magnetic materials do not sufficiently inhibit the leakage of unwanted radiation, and so further improvements are required to ensure compliance with regulatory radiation standards.

Claims

1. Charging device comprising a first loop (131) and a second loop (132) for wireless charging at a first resonant frequency, the charging device additionally comprising a first layer (135), the first and the second loop being embedded within the first layer.

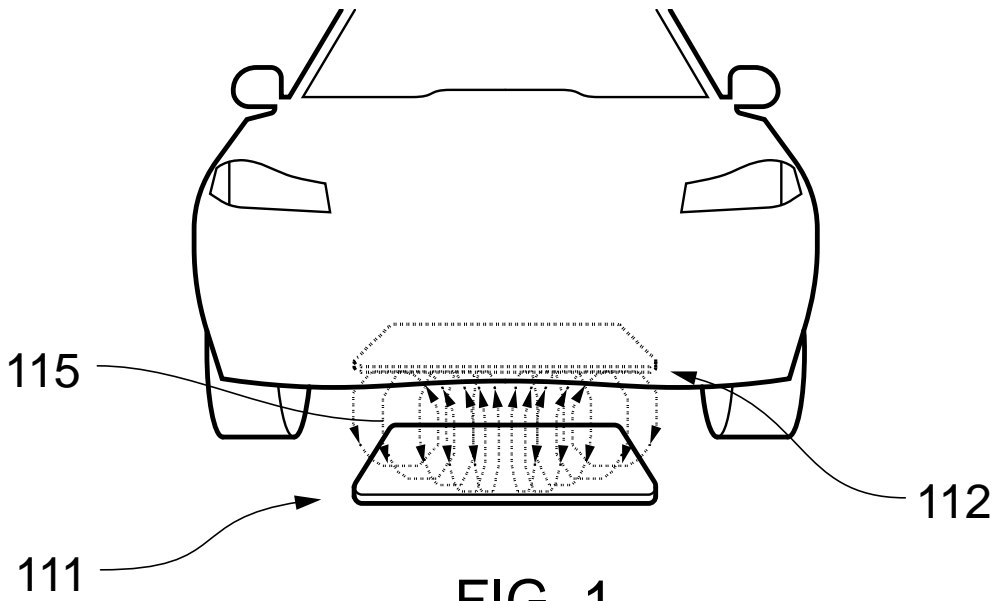

FIG. 1

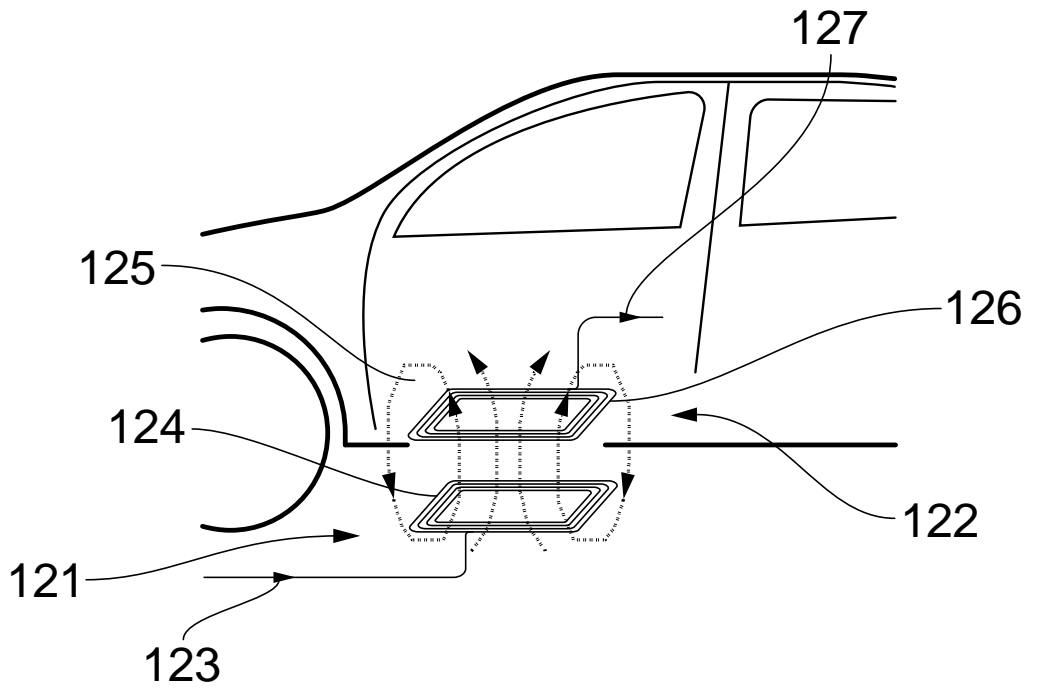

FIG. 2



FIG. 3

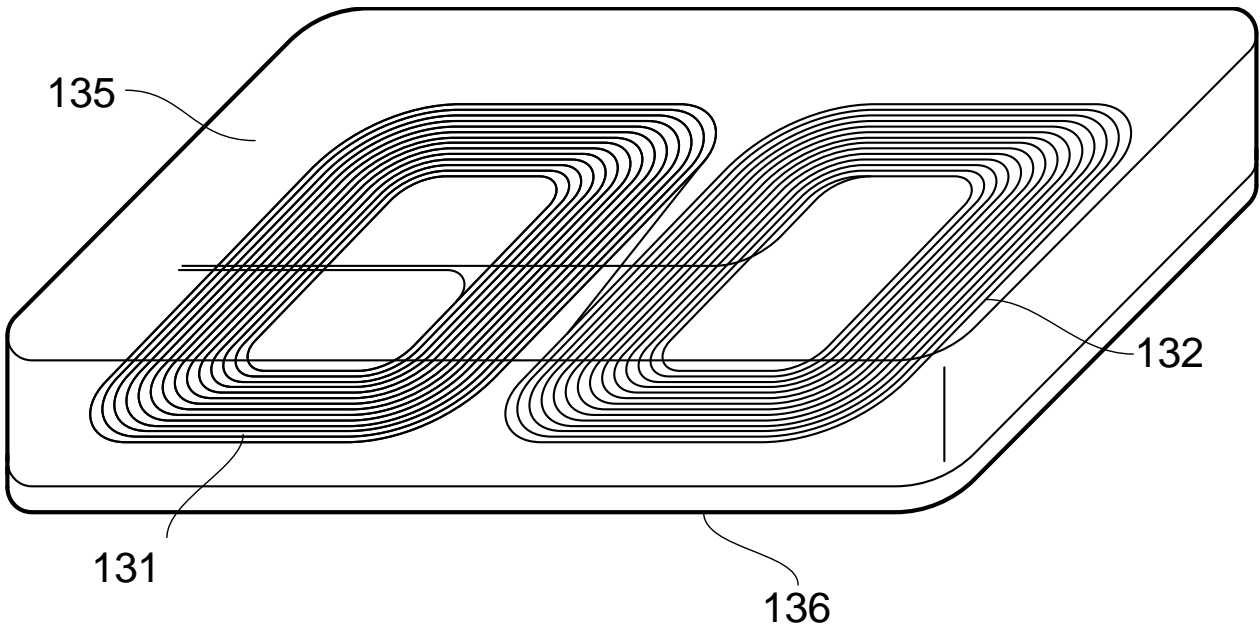

FIG. 4

(19) United States Patent and Trademark Office (USPTO)

- (21) Application number: **12/566 370**
(11) Publication number: **US10545718B1**
(40) Publication date: **December 1, 2019**
(22) Filing date: **June 1, 2018**
(30) Priority: **June 1, 2017 US 29/9792458**
(51) Int. Cl.: **H01F27/28, H01F1/15333, H01F1/20**
(71) Assignee: **Paddle Science Laboratories**
(72) Inventors: **Karl Steinmetz, Ludwig Latimer**

(54) Improved ground charging pad and car charging pad

[1] Fig. 1 illustrates a prior-art charging pad comprising a solenoid 311 and ferrite 312, a ceramic magnetic material.

[2] Recently it has been proposed to replace the single solenoid of a charging pad with a double-O solenoid. Admittedly, such a structure has drawbacks: it can be used only for resonant wireless charging and excludes many other winding topologies such as reverse windings for active shielding. However, sensitivity to misalignment is greatly reduced.

[3] Fig. 2 shows a ground charging pad modified to accommodate a double-O solenoid 321 over an enlarged ferrite layer 322. A polymer 323 encases the arrangement. The bottom of the encasing is provided with a rubber layer 333 to prevent lateral movement of the ground charging pad when it lies loosely on the floor of a garage. However, ferrites are brittle and heavy, and therefore ferrite layers of such size are unsuitable for a car charging pad.

[4] A charging pad according to the invention combines magnetic alloys with any polymer whose melting point is lower than that of the alloys. Polymers are not magnetic but have the advantage of being more flexible than ferrites.

[5] According to an embodiment, the polymer is TP.190, a thermoplastic with a melting point of 190°C. It is combined with grains made from alloys such as CoFeNi, FeCuSiB or NbSiBCo. Such alloys are magnetic and have a melting point of more than 400°C. Thus, a car charging pad according to the invention may be obtained in the following manner.

[6] First, the amorphous alloys are prepared and ground separately to obtain grains measuring between 1 micrometer and 1 millimeter. Next, TP.190 is prepared so that it is in the liquid phase and grains of the alloys in the desired proportions are mixed in. The mixture is extruded and then left to solidify in a mold to form a blank having the shape of a car charging pad. Many blanks can be obtained very efficiently in this manner.

[7] Next, as illustrated in Fig. 3, a robot arm 331 moves along a desired wire path on the blank 332. The robot arm has a heater head 333 which locally heats the blank to a temperature above the melting point of the polymer to create a liquified area 336.

[8] A wire feeder 334 behind the heater head lays the conductive wire 335 into the liquified area. As the robot arm moves forward, the polymer re-solidifies over the wire.

[9] In this manner a first solenoid with its windings is created and next to it a second solenoid with its windings. This is a double-O solenoid. It can be used in a charging pad if the shape of the wire path is chosen such that the two solenoids are tuned to the intended charging frequency.

[10] The resulting car charging pad is neither brittle nor heavy. In addition, the embedded wire is protected from spray water. Any way to reduce corrosion is welcome in the context of cars.

[11] We have found that it is advantageous to heat the grains of amorphous FeCuSiB to 390°C and let them cool down before mixing them with TP.190. These grains then contain crystal cells measuring between 150 nanometers and 300 nanometers. If these grains constitute 32 to 38% by weight of the blank, the resulting charging pad has a surprisingly high electromagnetic coupling strength. These grains, however, are sensitive to corrosion.

[12] In yet another embodiment a temperature-sensitive disconnecting switch may be embedded using the heater head. This enables the disconnection of the car charging pad if the magnetic material heats up because of thermal losses.

Claims

1. A charging pad comprising a nanocrystalline alloy made of magnetic grains and a polymer whose melting point is lower than that of the nanocrystalline alloy.

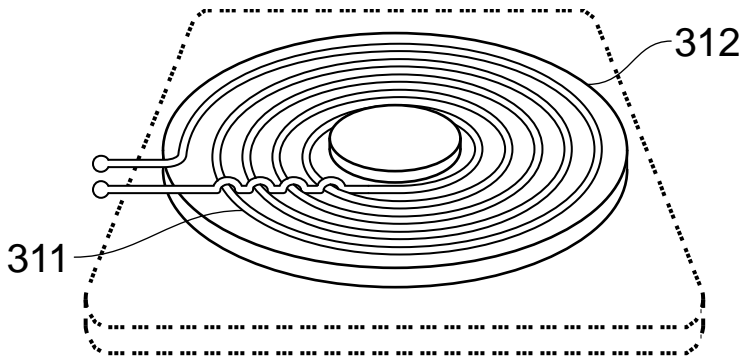

FIG. 1

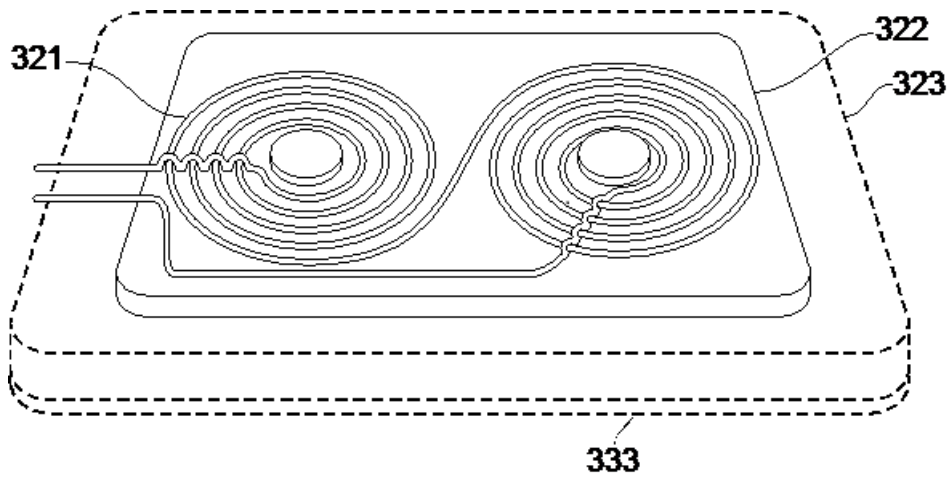

FIG. 2

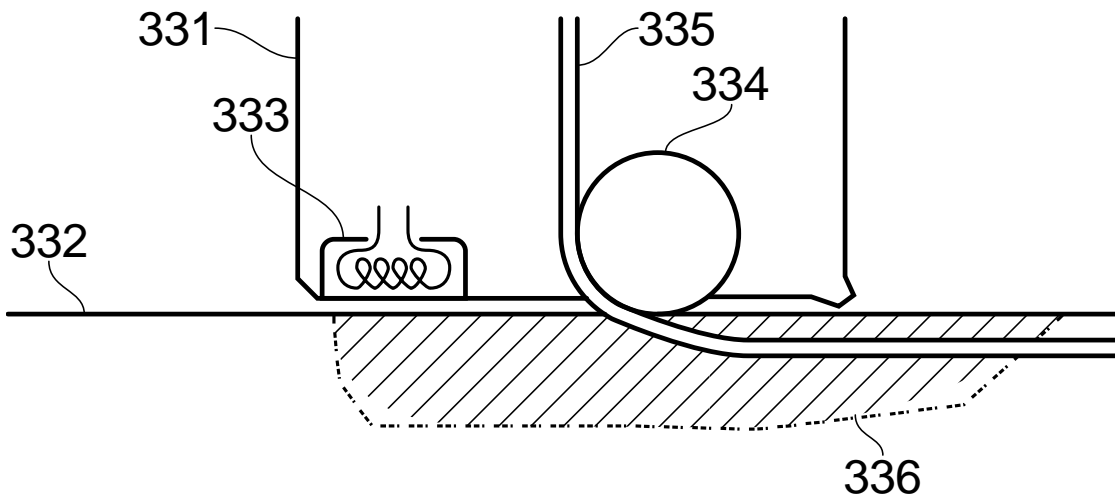

FIG. 3

(19) European Patent Office

(21) Application number:	20141421.3
(11) Publication number:	EP 3 513 705 A1
(45) Date of filing:	3 January 2020
(30) Priority:	15 January 2019 DE 101 6021 7663.4
(43) Date of publication:	22 July 2020
(51) Int. Cl.:	H02J50/70, H01F27/36
(71) Applicant:	Clarke & Ayrton Ltd.
(72) Inventor:	Wasita C. Atisaw, Lamesur E. Rusemal

(54) Solenoid with active shielding

[1] High power wireless charging pads need preventive measures against unwanted electromagnetic fields.

[2] Fig. 1 illustrates the configuration of a known charging pad. Fig. 2 illustrates the invention. Note that in Fig. 1 and Fig. 2 the dimensions are not to scale and the number of windings shown is for explanatory purposes only.

[3] Fig. 1 illustrates that known charging pads comprise a solenoid 411. A solenoid consists of a conductive trace with several concentric windings.

[4] Fig. 2 illustrates that a charging pad according to the invention comprises a solenoid 421 supplemented with reverse windings 422 for active shielding. They are wound concentrically around the solenoid but connected to have the reverse winding direction compared to the solenoid. When a current passes through the solenoid 421, the same current will pass through the reverse windings 422.

[5] This generates intentional additional electromagnetic fields which act as local neutralising fields during charging. We have found that leakage of unwanted radiation is reduced considerably.

[6] A solenoid with active shielding according to the invention may be supplemented by other means which further reduce leakage of unwanted radiation.

[7] For instance, it is well known that wireless charging pads benefit from having a metal sheet close to the solenoid as a layer of the charging pad. During operation, eddy currents are created within the metal sheet.

[8] The unwanted radiation is thereby locally neutralised. Irrespective of the exact configuration of the solenoid or the materials in the charging pad, such a metal sheet will reduce leakage of unwanted radiation.

Claims

1. Charging pad for wireless inductive charging in which the solenoid (421) is supplemented with reverse windings (422) which are wound concentrically around the solenoid with reverse polarity to the solenoid so that when a current passes through the solenoid, the same current will pass through the reverse windings.

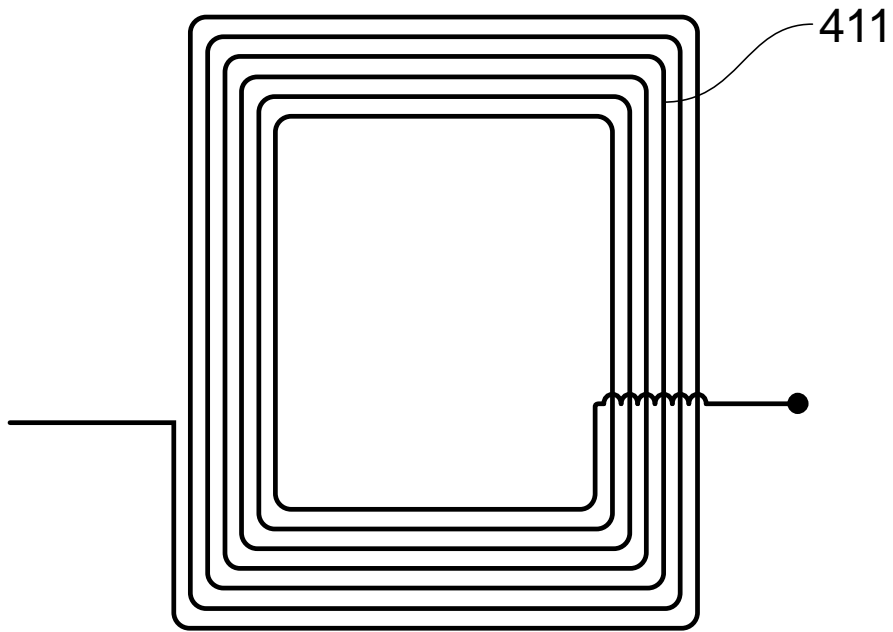

FIG. 1

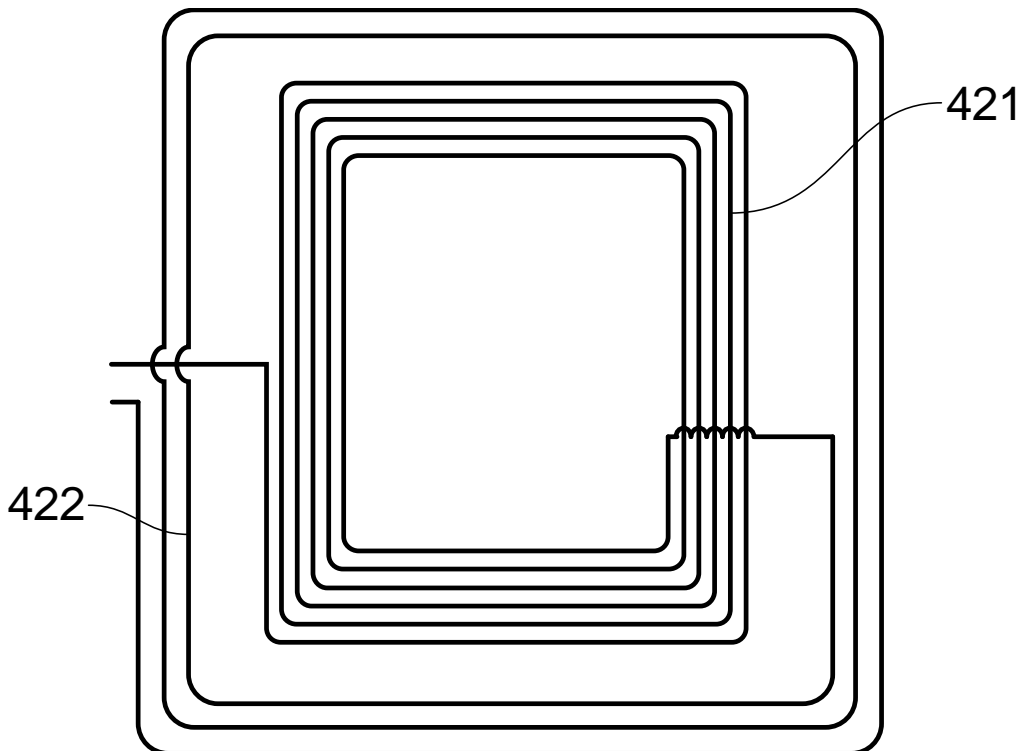

FIG. 2

Advertising brochure

Distributed with Lawn & Order, Journal for Xtreme Gardening,
vol. 01/2020, 13 Dec. 2019

[1] The electrically powered ORBIT is a robot mower for professional lawn care. Designed to mow up to 10 hectares per day, it greatly reduces the size of the fleet needed to maintain a golf course. Although a robot mower is not a car we've put the latest technology from automotive manufacturers and other high-tech companies into our latest model.

[2] The ORBIT comes equipped with a system for resonant wireless charging licensed from a leading car manufacturer. Unsafe metal contacts in the charging dock are now a thing of the past. Corrosion or short circuits because of wet cut grass or rainwater are no longer a problem either.

[3] There's no risk of unwanted electromagnetic radiation interfering with smart home equipment of your clients: the wireless charging system uses reverse windings for active shielding which are embedded in a protective magnetic material consisting of TP.190 at 52% by weight and nanocrystalline FeCuSiB and amorphous CoFeNi at a ratio of 2:1.

[4] This composition has been designed specifically to withstand corrosion caused by wet conditions. Another safety feature is the fact that you don't have to switch the charging dock on or off. The charging dock contains a pressure sensor which activates the charging pads as soon as the ORBIT moves into the dock.

[5] To detect obstacles and dangerous objects, a sensing system (see the arrow in Fig. 1) mounted at the front of the ORBIT continuously monitors the robot's surroundings. The sensing system can be an ultrasound sensing system (USS) or a resonant sensing system (RSS).

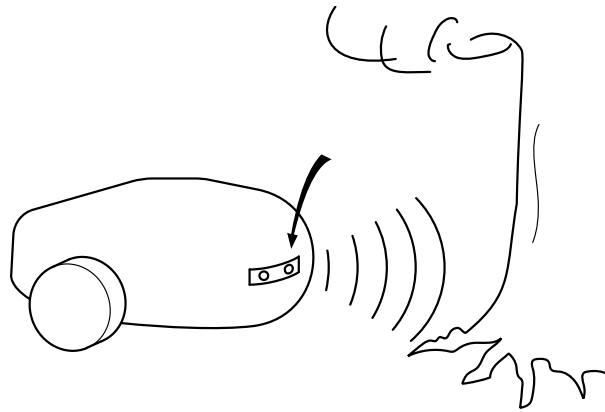

Fig. 1: ORBIT with sensing system (see arrow)

[6] The USS works by continuously emitting an ultrasound sensing field. If the sensing field is reflected by a sufficiently large obstacle, the reflected field affects a detection current in a detection transducer also mounted at the front of the robot. The obstacle creates changes in the detection current as the ORBIT approaches.

[7] Downstream of the sensing system (see Fig. 2) the detection current is continuously measured by a sampling circuit and forwarded as a signal to a microprocessor. This microprocessor is programmed to evaluate whether a detected change means that the robot is approaching an obstacle or not.

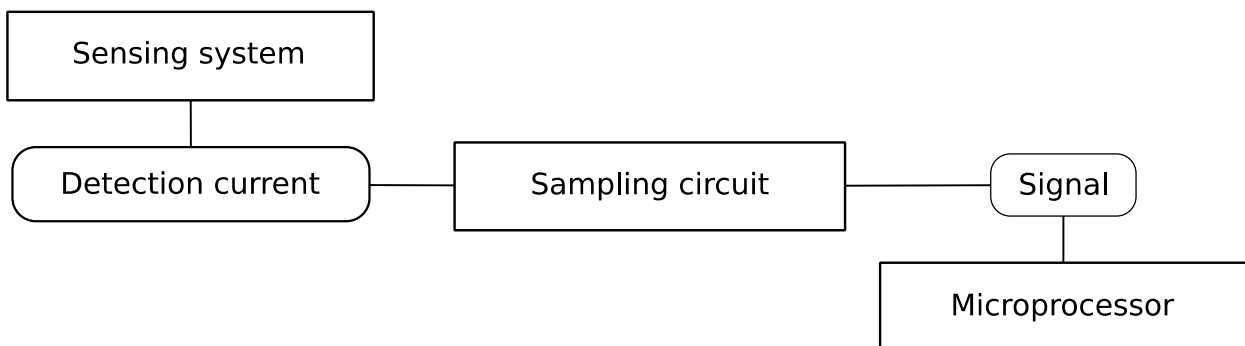

Fig. 2: Circuit diagram

[8] The RSS is an upgrade which can be retrofitted to replace the USS, for instance during routine maintenance. The circuit components downstream of the sensing system function independently of whether USS or RSS is used. No changes to the robot's body are required.

[9] The RSS works by continuously sending an excitation current into an excitation solenoid tuned to 500 kHz to generate a nearby electromagnetic sensing field. An obstacle such as a cat or a beer can left on the lawn affects the electromagnetic sensing field as the ORBIT approaches.

[10] A probing solenoid is mounted in proximity to the excitation solenoid and is also tuned to 500 kHz. The probing solenoid continuously picks up the sensing field and creates a detection current which reacts to any changes in the sensing field.

[11] Thus an obstacle affecting the sensing field leads to corresponding changes in the detection current as the ORBIT approaches.

[12] Resonant sensing has several advantages. Pets are reliably detected because a living body strongly distorts the sensing field. Resonant sensing also reliably detects metal objects, so it will protect your mower's blades. Once an obstacle is detected the microprocessor instructs the robot to turn and go in a different direction. The RSS operates at 500 kHz, while the coils in the charging pads have a layout so that they are tuned to the charging frequency of 85 kHz. This means there is no risk of harmful interference.

[13] When the microprocessor detects a low battery charge, it sends the ORBIT back to its charging station. If the charging pad is blocked by an obstacle (such as your cat), the sensing system emits a warning sound and/or light to alert you (and maybe scare your cat away).