

## EUROPEAN QUALIFYING EXAMINATION 2024

# Paper C

## Part 2

This paper contains:

- |                          |                  |
|--------------------------|------------------|
| * Letter of the opponent | 2024/C2/EN/1-2   |
| * Annex 1                | 2024/C2/EN/3-13  |
| * Annex 2                | 2024/C2/EN/14-18 |
| * Annex 3                | 2024/C2/EN/19-23 |
| * Annex 4                | 2024/C2/EN/24-27 |
| * Annex 5                | 2024/C2/EN/28-30 |
| * Annex 6                | 2024/C2/EN/31-34 |
| * Annex 7                | 2024/C2/EN/35-38 |

Encrypted email from:

Mr. Stael Kaolin  
Paddle Science Laboratories  
481 8th Avenue  
New York 10001-1809  
USA

To: Ms. Molly Dorsett Pauley  
European Patent Attorney  
Todiet Kwiscus LLC  
Upper Coxley  
Wells BA5 1QS  
Great Britain

Sent: Thursday, 14 March 2024 11:30

Subject: Opposition against EP3831740B1

Dear Ms. Pauley,

Our systems are back online and I am now sending you a complete version of document EP 3831740B1 (Annex 1). Please now prepare the second part of the notice of opposition so that it can be combined with the first part you have sent me already.

I was now able to finalize my analysis of the file history of Annex 1. Here is all the relevant information for the further parts of Annex 1, i.e. paragraphs 21 to 33, figures 5 and 6, and claims 4 to 7:

Annex 1 claims the priority of applications NO20200113 and NO20200355.

NO20200113 does not contain any of the further parts of Annex 1. NO20200355 contains the following further parts of Annex 1 (the numbering refers to Annex 1): paragraphs 21 - 23, figures 5 and 6, claims 4 and 5.

I again attach Annexes 2 to 5 and additionally Annexes 6 and 7, which I just received from a colleague.

My colleague spent the better part of the morning on the transcription in Annex 6. We also have a digital copy of the podcast downloaded from <https://www.podcloud.com/BBC9/programmes/b07dx75g/20200430.ogg>

Kind regards,

Stael Kaolin

**Annexes**

Annex 1 (A1) EP 3 831 740 B1

Annex 2 (A2) EP 3 781 517 A1

Annex 3 (A3) US 10545718 B1

Annex 4 (A4) EP 3 513 705 A1

Annex 5 (A5) Advertising brochure

Annex 6 (A6) Transcript of podcast

Annex 7 (A7) EP 3 631 538 A1

(19)



**Europäisches Patentamt**  
**European Patent Office**  
**Office européen des brevets**

(11) **EP 3 831 740 B1**

(12)

**EUROPEAN PATENT SPECIFICATION**

(45) Date of publication and mention  
of the grant of the patent:  
**14 June 2023 Bulletin 2023/24**

(51) Int. Cl. : **H02J50/12,**  
**H01F1/15333,**  
**H04B5/0043,**  
**B60L53/124,**  
**B60L53/64**

(21) Application number: **20453334.5**

(22) Date of filing: **25 July 2020**

(54) **Wireless charging pad**  
**Kabellose Ladeplatte**  
**Plaque de charge sans fil**

(84) Designated Contracting States:  
**AL AT BE BG CH CY CZ DE DK EE**  
**ES FI FR GB GR HR HU IE IS IT LI**  
**LT LU LV MC ME MK MT NL NO PL**  
**PT RO RS SE SI SK SM TR**

(30) Priority:  
**14 March 2020 NO20200113**  
**25 May 2020 NO20200355**

(43) Date of publication of application:  
**4 August 2021 Bulletin 2021/31**

(71) Applicant:  
**Mute&Mancer Corp**  
**Winterstr. 23**  
**1984 Rioneuro (LT)**

(72) Inventor:  
**C. Estsec, Bolt O. Nipswich**

(73) Proprietor:  
**Mute&Mancer Corp**

(74) Representative:  
**Slart Bartifast**  
**29 Arlington Avenue**  
**London N1 7BE (GB)**

Note: Within nine months of the publication of the mention of the grant of the European patent in the European Patent Bulletin, any person may give notice to the European Patent Office of opposition to that patent, in accordance with the Implementing Regulations. Notice of opposition shall not be deemed to have been filed until the opposition fee has been paid (Art. 99(1) European Patent Convention).

[1] This invention concerns charging a battery of a battery-powered car. The conventional way to charge such a battery is using plug-socket systems, which require plugging a cable into a socket of the car and into a socket of a charging terminal providing the electric energy needed.

[2] Plug-socket systems have several safety features. For instance, protective reinforcements of the cable ensure mechanical resistance. In addition, switches in the charging terminal make it possible to keep the cable free from electrical energy unless the battery is being charged. However, inserting the plug into the socket requires manual user interaction, which comes with risks.

[3] This disadvantage can be avoided with wireless charging, which is illustrated in Fig. 1. Energy to charge the battery is transmitted without wires from a ground charging pad 111 to a car charging pad 112 by electromagnetic fields 115.

[4] To compete with plug-socket systems in terms of charging speed and energy efficiency, the charging pads each have to contain a coil for resonant wireless charging. The resulting concept is illustrated in Fig. 2.

[5] A transmitting charging pad 121 and a receiving charging pad 122 are brought close together. Both pads comprise a coil, which is a conductive trace with several concentric windings. Electric energy 123 to be transmitted is sent into coil 124 as an alternating current at a charging frequency. Coil 124 thereby produces an alternating electromagnetic field with field lines 125 which also pass through coil 126.

[6] Each of the coils is a coil for resonant wireless charging. To have this property, a coil has to have a layout such that it is tuned to the charging frequency. The electromagnetic fields passing through both coils thereby establish a resonant link between the charging pads. This allows extracting electric energy 127.

[7] For optimum electromagnetic coupling strength, a charging pad has to be well aligned with its opposite charging pad. Reducing sensitivity to misalignment is difficult with the arrangement shown in Fig. 2.

[8] Fig. 3 and Fig. 4 show aspects of a charging pad according to the invention. As is typical in this technical field, only a few windings are shown; a real device may contain more. The opposite charging pad is not shown in Fig. 3 and Fig. 4.

[9] A charging pad according to an embodiment of the invention comprises a first coil 131 and second coil 132, both for resonant wireless charging, the first coil and the second coil being arranged side by side. This arrangement is more complex than that of a charging pad with a single coil. However, it reduces sensitivity to misalignment and increases electromagnetic coupling strength without requiring a larger charging pad.

[10] The charging pad according to the embodiment of the invention also comprises a first layer 135 made of a magnetic material, the first coil and the second coil having been placed on a first surface of the first layer and the first layer has been treated so that the first coil and the second coil have sunk into the first layer. For instance, the first layer may initially be liquid and solidify after provision of the coils. Although the coils may end up not being completely covered, they effectively become surrounded by the magnetic material.

[11] Magnetic material, i.e. any material having at least some magnetic or magnetisable particles, generally has the beneficial effect of increasing the strength of the electromagnetic coupling to the coil of the opposite charging pad. The magnetic material in the embodiment of the invention is a composite comprising suitable amounts of an alloy of cobalt, iron and nickel (CoFeNi) and an alloy of iron, copper, silicon and boron (FeCuSiB). Such a composite has been found to have superior electromagnetic coupling strength if CoFeNi is amorphous and FeCuSiB is nanocrystalline.

[12] A composite having very good long-term mechanical stability is obtained if nanocrystalline FeCuSiB is 30 - 40% by weight of the material. However, FeCuSiB has a high oxidation susceptibility, which entails the problem of corrosion sensitivity.

[13] For such a composite the use of at least 10% amorphous CoFeNi by weight of the material has the surprising effect of preventing oxidation of FeCuSiB. However, too much CoFeNi worsens the long-term mechanical stability, and therefore the amount of amorphous CoFeNi has to be below 20% by weight of the material for such a composite.

[14] An alternative composite having high thermal tolerance is obtained if the amount of amorphous CoFeNi is more than 20% and less than 30% by weight of the material. In this case it is necessary to include 20 - 30% nanocrystalline FeCuSiB by weight of the material; otherwise the composite is not usable because of insufficient long-term mechanical stability.

[15] In an embodiment of the invention, the magnetic material is magnetisable concrete. This is magnetic material comprising cement and having a density of at least 2000 kg/m<sup>3</sup>.

[16] The charging pad may comprise a second layer 136 next to the first layer.

[17] Magnetisable concrete is too heavy for a car charging pad but it has the same abrasion resistance and thermal expansion coefficient as standard road surface materials. This is beneficial for installation in public environments where ground charging pads remain permanently in the same place and position.

[18] However, the typical magnetisable concrete does not sufficiently inhibit the leakage of unwanted radiation, and so further improvements are required to ensure compliance with regulatory radiation standards.

[19] The second layer 136 may be made of an electrically conductive material, for instance metal. Within such a second layer neutralising currents, known as eddy currents, are created which locally cancel the unwanted radiation.

[20] Leakage of unwanted radiation is thereby reduced. A combination with other measures to reduce leakage of unwanted radiation may be useful to ensure compliance with regulatory radiation standards.

[21] The invention also relates to a system according to claim 4 and a method according to claim 5.

[22] Fig. 5 illustrates metallic objects and living beings exposed to the electromagnetic field in the charging area 141 between charging pads 142 and 143. Previously, it would have been the task of a human user to monitor this area, requiring attention and visual access.

[23] Fig. 6 illustrates a charging system according to the invention. It may have all the features of claim 1 but at least comprises a first coil 151 for resonant wireless charging. The charging system also comprises a processing unit 152 and a detection circuit comprising a plurality of second coils 153a, 153b, 153c for resonant sensing.

[24] While the first coil is responsible for transferring energy, the second coils make it possible to detect whether a foreign object enters the charging area. The second coils function independently of the first coil, because coils for resonant sensing have a layout such that they are tuned to a different resonant frequency compared to coils for resonant charging.

[25] According to the invention, a first of said second coils is configured to create a sensing field. Fig. 6 illustrates that a generator 154 generates an excitation current in coil 153a. A resonant sensing field is thereby created which is influenced when foreign objects enter the charging area.

[26] The invention exploits the fact that the sensing field interacts with materials having dielectric properties, such as living beings, or conductive properties, such as metal objects.



[27] Fig. 6 also illustrates that a second of said second coils is configured to probe said sensing field. Second coil 153b or second coil 153c picks up the sensing field and thereby creates a detection current which is measured by a measuring component 155. A corresponding signal is provided to the processing unit.

[28] A sudden change in the measurement value is evidence that the sensing field has been disturbed. This reliably indicates that an animal or a human body part, or a metal object such as a beer can, has just entered the charging area.

[29] The processing unit continuously receives and continuously evaluates the measurement value. This enables automation of the mental act of deciding whether the battery should be charged or not. However, this does not yet solve the technical problem of inadvertent field exposure in the charging area.

[30] Accordingly, the invention also relates to a method for controlling a charging system to selectively charge a battery of an electric vehicle. The method uses a processing unit. A wireless data link may cause an electrical connection outside the electric vehicle to be inactive, based on what the processing unit decides. As a result, the charging area is free of any charging field, preventing inadvertent field exposure.

[31] Preferably, the charging system is the charging system according to claim 4.

[32] Modern electric vehicles typically have an onboard computer or a microprocessor, both of which may work as said processing unit. Given appropriate instructions, the processing unit will execute the method of the invention using the signal provided by the detection circuit or based on any other type of signal related to the charging process.

[33] For instance, the received signal may be representative of the price of electric energy to be used for charging the battery. This provides a solution to the problem of reducing costs because of the desirable effect that charging can be inhibited if the price is higher than a predetermined value.

Claims 1 to 7 only available on screen

Claims 1 to 7 only available on screen

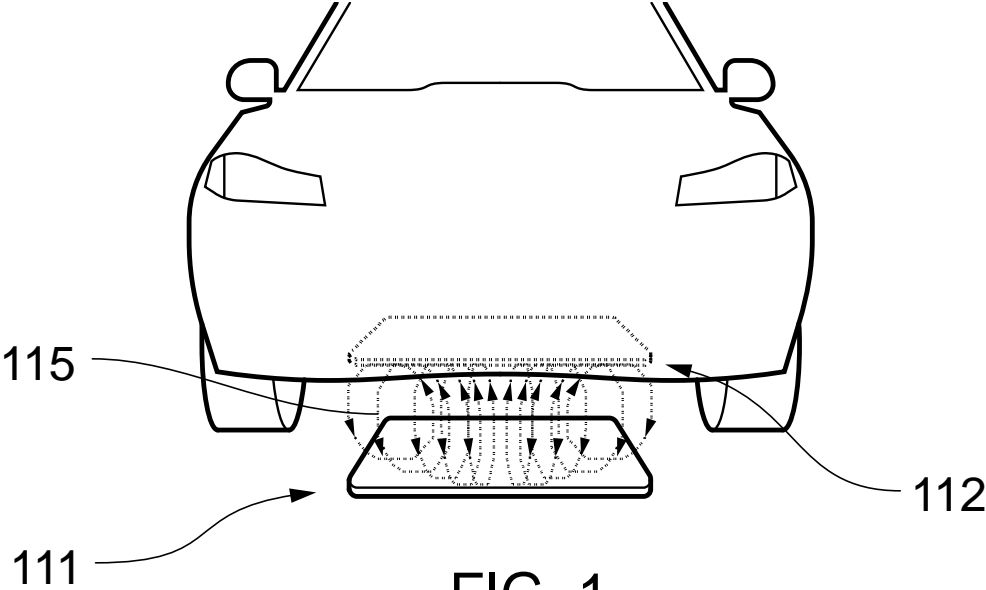

FIG. 1

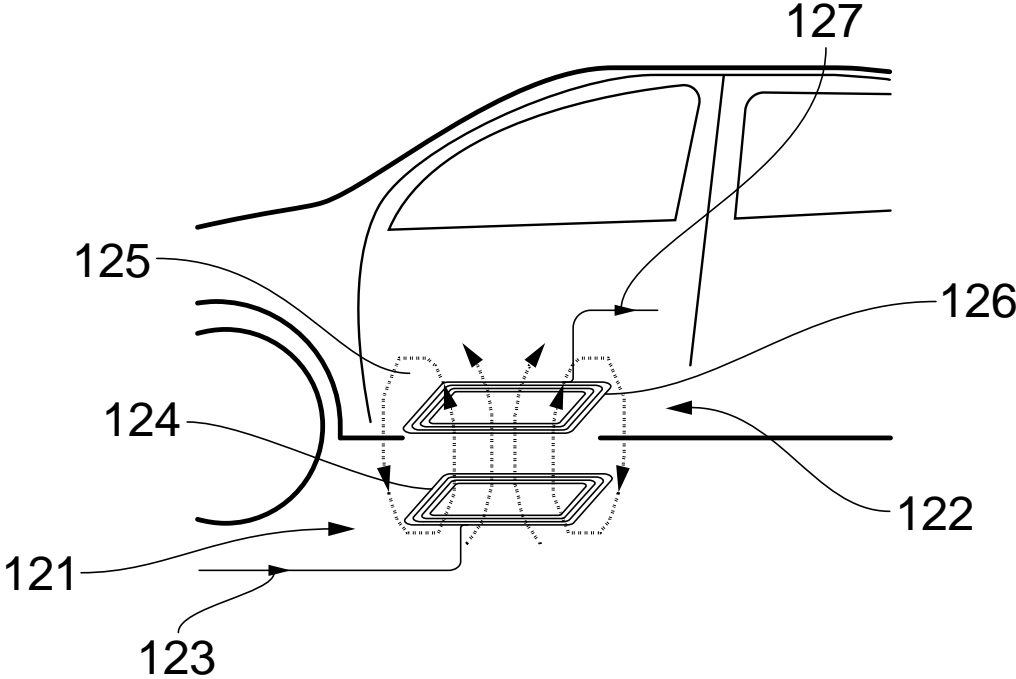

FIG. 2



FIG. 3

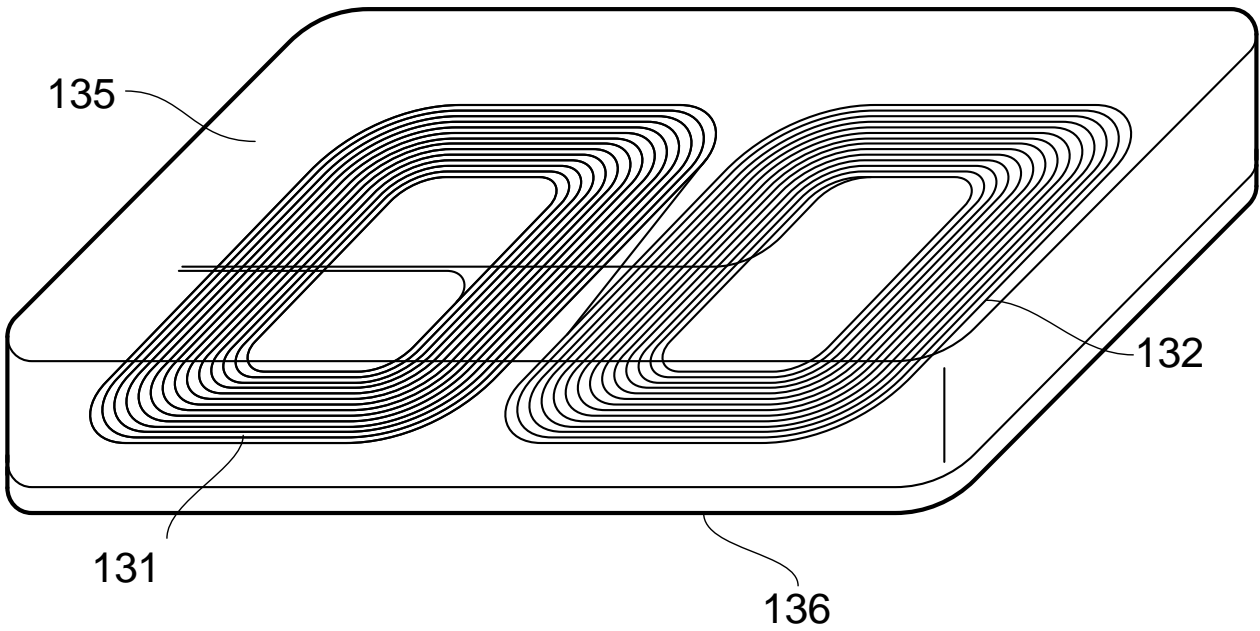
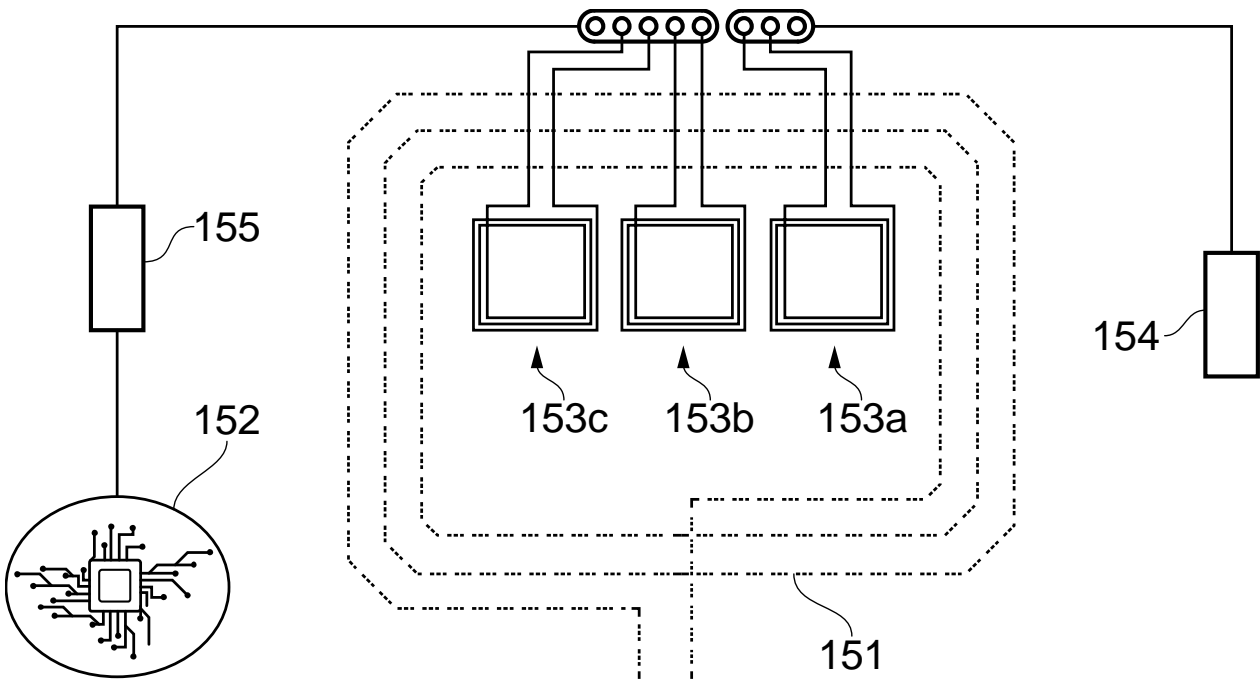
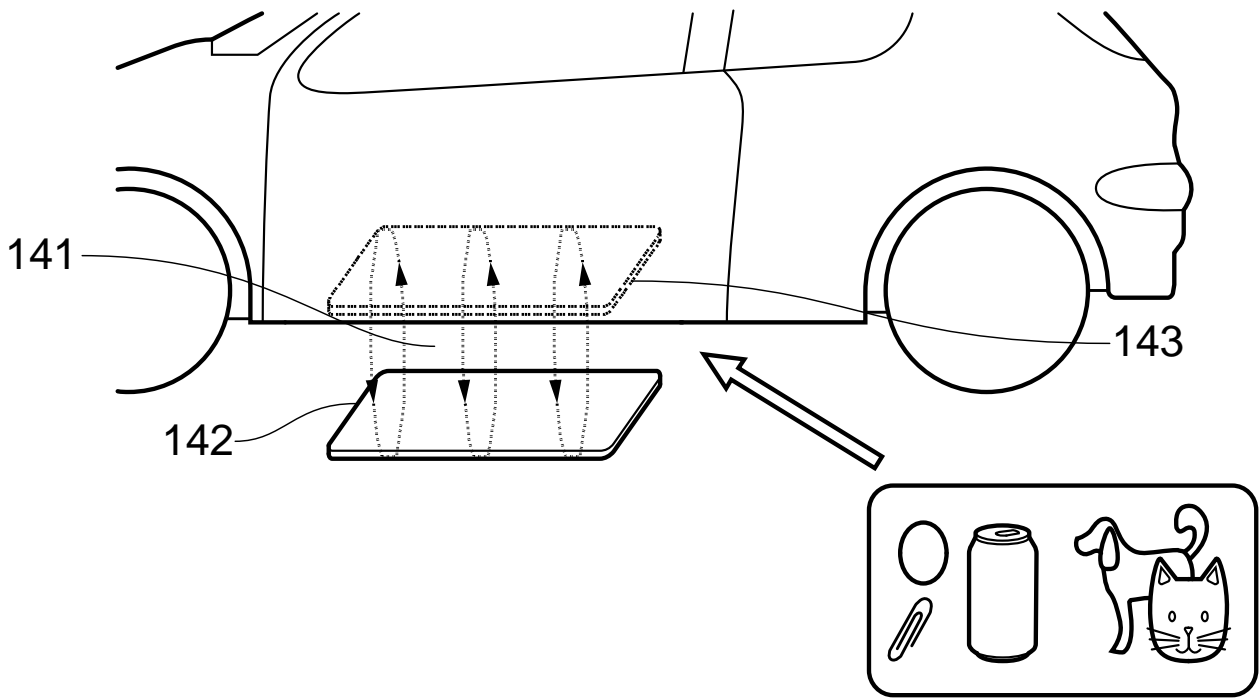

FIG. 4



**(19) European Patent Office**

(21) Application number:	<b>20173205.0</b>
(11) Publication number:	<b>EP 3 781 517 A1</b>
(45) Date of filing:	<b>6 January 2020</b>
(43) Date of publication:	<b>29 July 2020 / Bulletin 2020/26</b>
(30) Priority:	<b>18 January 2019 EP19732000.1</b>
(51) Int. Cl.:	<b>H01F27/28, H01F1/14766</b>
(71) Applicant:	<b>Mute&amp;Mancer Corp</b>
(72) Inventor:	<b>Puristsaf T. Fastsirup, C. Estsec</b>

**(54) Charging pad**

[1] Wireless charging is increasingly used to provide energy for the battery in a battery-powered vehicle. A vehicle is a device for carrying objects or individuals, such as a car.

[2] A charging pad according to an embodiment of the invention comprises a first coil 131 and second coil 132, both for resonant wireless charging, the first and the second coil being arranged side by side.

[3] The charging pad according to the embodiment of the invention also comprises a first layer 135 made of a magnetic material, the first coil and the second coil having been placed on a first surface of the first layer and the first layer has been treated so that the first coil and the second coil have sunk into the first layer. Although the coils may end up not being completely covered, they effectively become surrounded by the magnetic material.

[4] The magnetic material in the embodiment of the invention is a composite comprising suitable amounts of an alloy of cobalt, iron and nickel (CoFeNi) and an alloy of iron, copper, silicon and boron (FeCuSiB). Preferably, the magnetic material comprises grains of amorphous CoFeNi at 20 - 30% and nanocrystalline FeCuSiB at 20 - 30% by weight of the magnetic material.

[5] Nanocrystalline alloys were discovered in 1993 and are characterised by having crystal cells smaller than 1 micrometre. It is generally known that amorphous alloys are alloys without crystal cells. Grains, sometimes called particles, are typically larger than 1 micrometre.

[6] In an aspect of the invention, the magnetic material has a density of at least 2000 kg/m<sup>3</sup> and comprises cement and magnetic particles.

[7] The charging pad may comprise a second layer 136 next to the first layer.

[8] However, typical magnetic materials do not sufficiently inhibit the leakage of unwanted radiation, and so further improvements are required to ensure compliance with regulatory radiation standards.



## Claims

1. Charging device comprising a first loop (131) and a second loop (132) for wireless charging at a first resonant frequency, the charging device additionally comprising a first layer (135), the first and the second loop being embedded within the first layer.

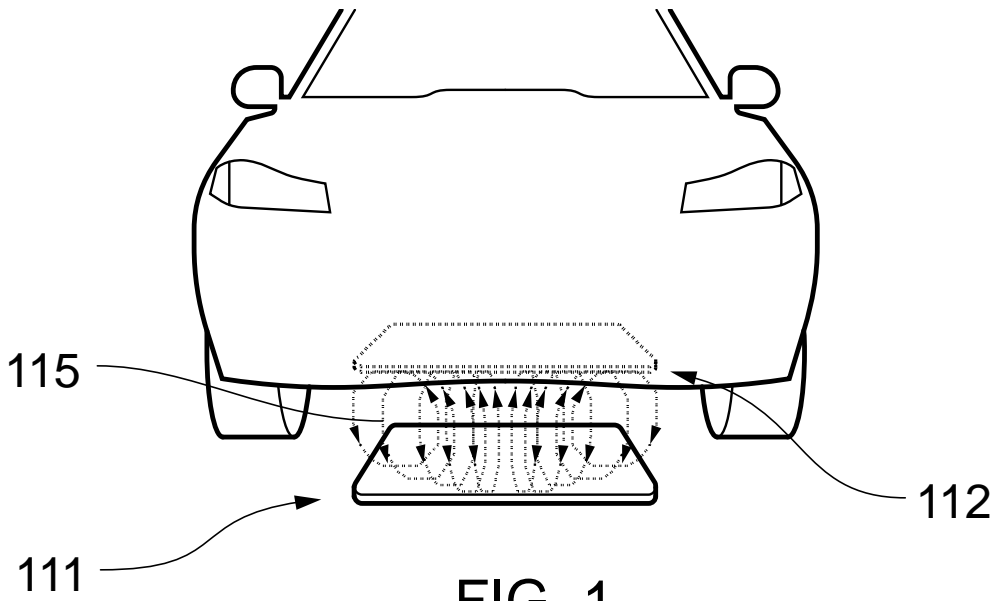

FIG. 1

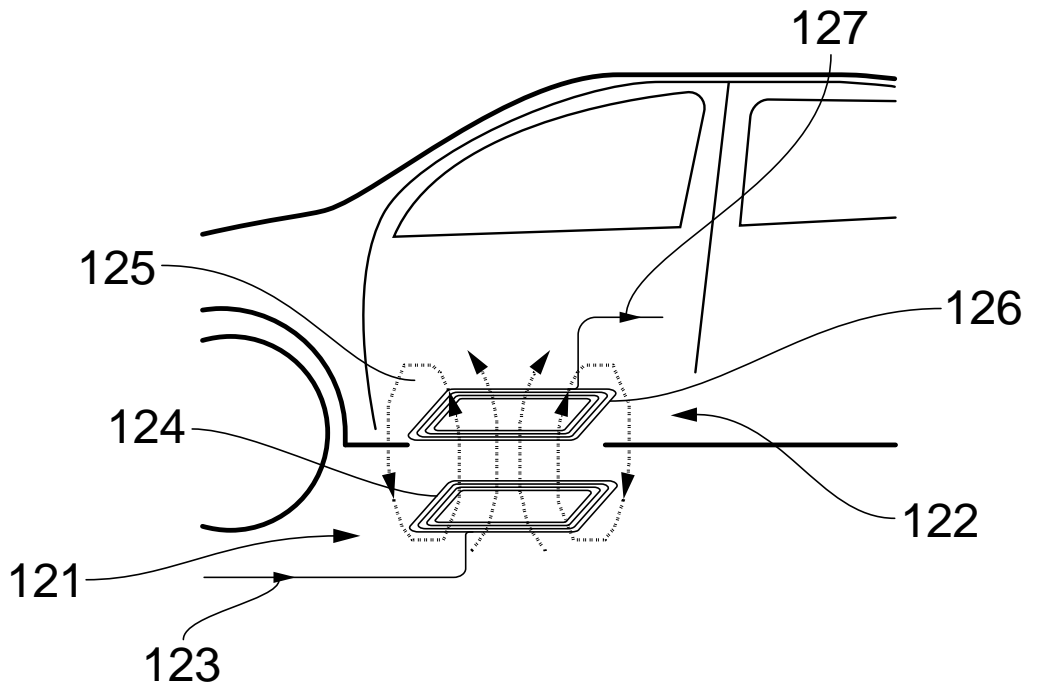

FIG. 2



FIG. 3

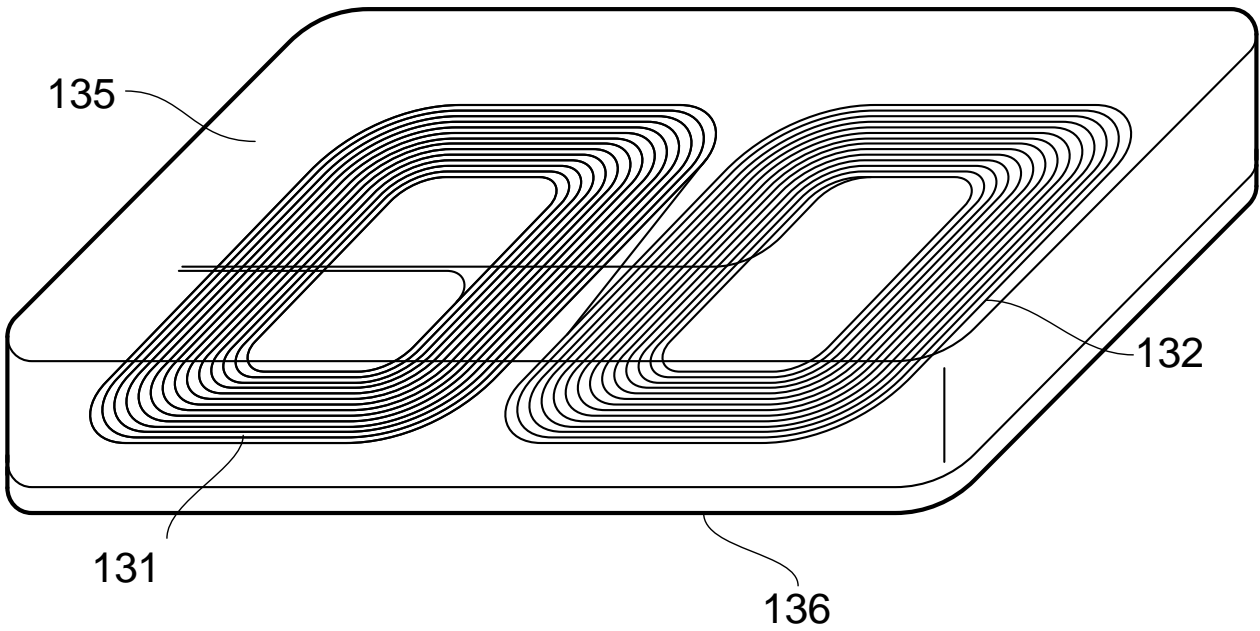

FIG. 4

**(19) United States Patent and Trademark Office (USPTO)**

- (21) Application number: **12/566 370**  
(11) Publication number: **US10545718B1**  
(40) Publication date: **December 1, 2019**  
(22) Filing date: **June 1, 2018**  
(30) Priority: **June 1, 2017 US 29/9792458**  
(51) Int. Cl.: **H01F27/28, H01F1/15333, H01F1/20**  
(71) Assignee: **Paddle Science Laboratories**  
(72) Inventors: **Karl Steinmetz, Ludwig Latimer**

**(54) Improved ground charging pad and car charging pad**

[1] Fig. 1 illustrates a prior-art charging pad comprising a solenoid 311 and ferrite 312, a ceramic magnetic material.

[2] Recently it has been proposed to replace the single solenoid of a charging pad with a double-O solenoid. Admittedly, such a structure has drawbacks: it can be used only for resonant wireless charging and excludes many other winding topologies such as reverse windings for active shielding. However, sensitivity to misalignment is greatly reduced.

[3] Fig. 2 shows a ground charging pad modified to accommodate a double-O solenoid 321 over an enlarged ferrite layer 322. A polymer 323 encases the arrangement. The bottom of the encasing is provided with a rubber layer 333 to prevent lateral movement of the ground charging pad when it lies loosely on the floor of a garage. However, ferrites are brittle and heavy, and therefore ferrite layers of such size are unsuitable for a car charging pad.

[4] A charging pad according to the invention combines magnetic alloys with any polymer whose melting point is lower than that of the alloys. Polymers are not magnetic but have the advantage of being more flexible than ferrites.

[5] According to an embodiment, the polymer is TP.190, a thermoplastic with a melting point of 190°C. It is combined with grains made from alloys such as CoFeNi, FeCuSiB or NbSiBCo. Such alloys are magnetic and have a melting point of more than 400°C. Thus, a car charging pad according to the invention may be obtained in the following manner.

[6] First, the amorphous alloys are prepared and ground separately to obtain grains measuring between 1 micrometer and 1 millimeter. Next, TP.190 is prepared so that it is in the liquid phase and grains of the alloys in the desired proportions are mixed in. The mixture is extruded and then left to solidify in a mold to form a blank having the shape of a car charging pad. Many blanks can be obtained very efficiently in this manner.

[7] Next, as illustrated in Fig. 3, a robot arm 331 moves along a desired wire path on the blank 332. The robot arm has a heater head 333 which locally heats the blank to a temperature above the melting point of the polymer to create a liquified area 336.

[8] A wire feeder 334 behind the heater head lays the conductive wire 335 into the liquified area. As the robot arm moves forward, the polymer re-solidifies over the wire.

[9] In this manner a first solenoid with its windings is created and next to it a second solenoid with its windings. This is a double-O solenoid. It can be used in a charging pad if the shape of the wire path is chosen such that the two solenoids are tuned to the intended charging frequency.

[10] The resulting car charging pad is neither brittle nor heavy. In addition, the embedded wire is protected from spray water. Any way to reduce corrosion is welcome in the context of cars.

[11] We have found that it is advantageous to heat the grains of amorphous FeCuSiB to 390°C and let them cool down before mixing them with TP.190. These grains then contain crystal cells measuring between 150 nanometers and 300 nanometers. If these grains constitute 32 to 38% by weight of the blank, the resulting charging pad has a surprisingly high electromagnetic coupling strength. These grains, however, are sensitive to corrosion.

[12] In yet another embodiment a temperature-sensitive disconnecting switch may be embedded using the heater head. This enables the disconnection of the car charging pad if the magnetic material heats up because of thermal losses.

## Claims

1. A charging pad comprising a nanocrystalline alloy made of magnetic grains and a polymer whose melting point is lower than that of the nanocrystalline alloy.

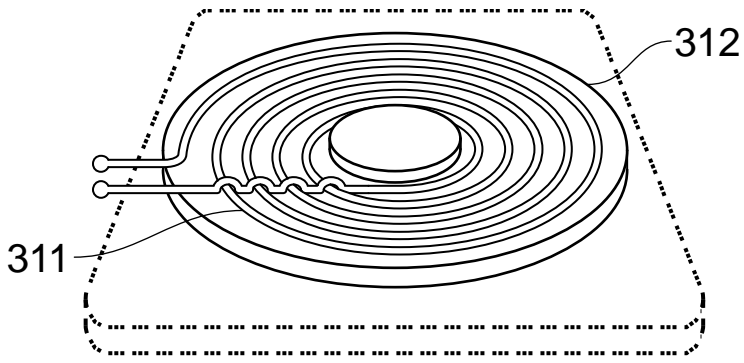

FIG. 1

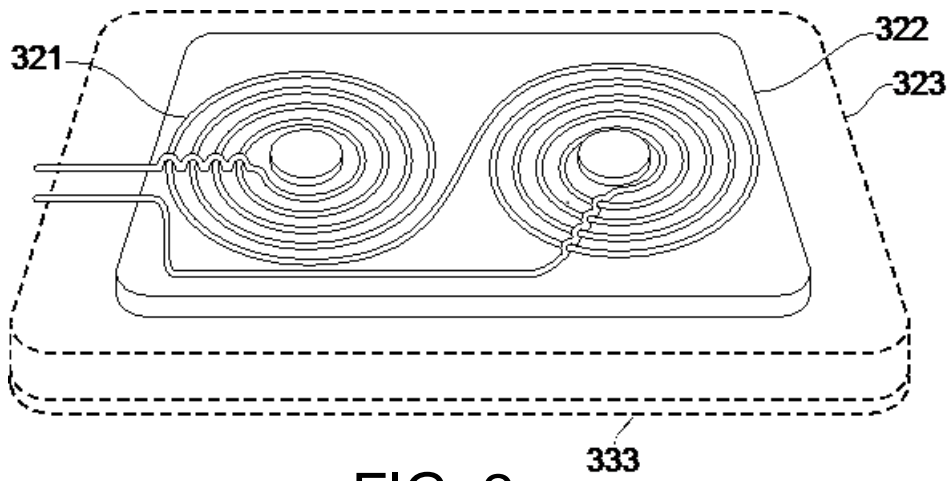

FIG. 2

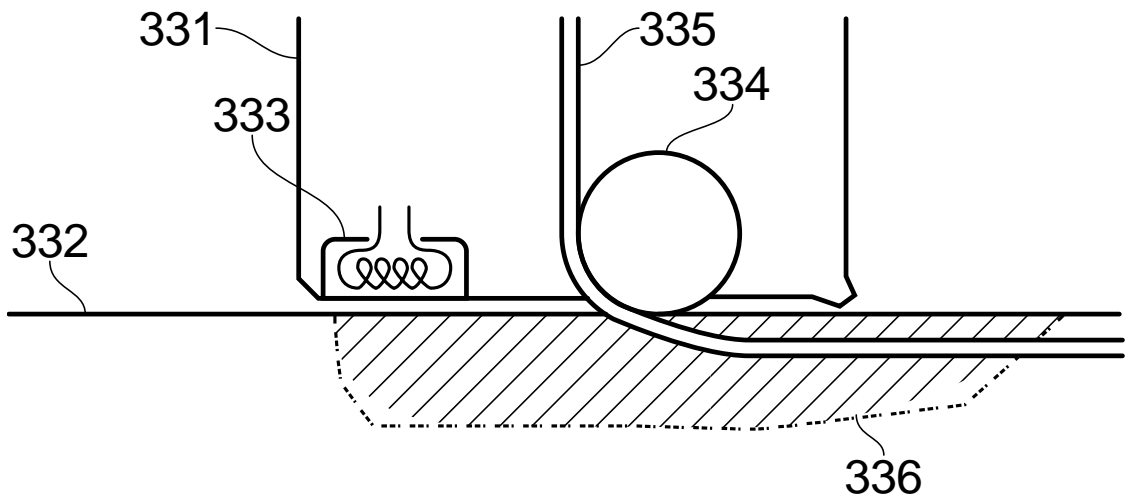

FIG. 3



**(19) European Patent Office**

(21) Application number:	<b>20141421.3</b>
(11) Publication number:	<b>EP 3 513 705 A1</b>
(45) Date of filing:	<b>3 January 2020</b>
(30) Priority:	<b>15 January 2019 DE 101 6021 7663.4</b>
(43) Date of publication:	<b>22 July 2020</b>
(51) Int. Cl.:	<b>H02J50/70, H01F27/36</b>
(71) Applicant:	<b>Clarke &amp; Ayrton Ltd.</b>
(72) Inventor:	<b>Wasita C. Atisaw, Lamesur E. Rusemal</b>

**(54) Solenoid with active shielding**

[1] High power wireless charging pads need preventive measures against unwanted electromagnetic fields.

[2] Fig. 1 illustrates the configuration of a known charging pad. Fig. 2 illustrates the invention. Note that in Fig. 1 and Fig. 2 the dimensions are not to scale and the number of windings shown is for explanatory purposes only.

[3] Fig. 1 illustrates that known charging pads comprise a solenoid 411. A solenoid consists of a conductive trace with several concentric windings.

[4] Fig. 2 illustrates that a charging pad according to the invention comprises a solenoid 421 supplemented with reverse windings 422 for active shielding. They are wound concentrically around the solenoid but connected to have the reverse winding direction compared to the solenoid. When a current passes through the solenoid 421, the same current will pass through the reverse windings 422.

[5] This generates intentional additional electromagnetic fields which act as local neutralising fields during charging. We have found that leakage of unwanted radiation is reduced considerably.

[6] A solenoid with active shielding according to the invention may be supplemented by other means which further reduce leakage of unwanted radiation.

[7] For instance, it is well known that wireless charging pads benefit from having a metal sheet close to the solenoid as a layer of the charging pad. During operation, eddy currents are created within the metal sheet.

[8] The unwanted radiation is thereby locally neutralised. Irrespective of the exact configuration of the solenoid or the materials in the charging pad, such a metal sheet will reduce leakage of unwanted radiation.

## Claims

1. Charging pad for wireless inductive charging in which the solenoid (421) is supplemented with reverse windings (422) which are wound concentrically around the solenoid with reverse polarity to the solenoid so that when a current passes through the solenoid, the same current will pass through the reverse windings.

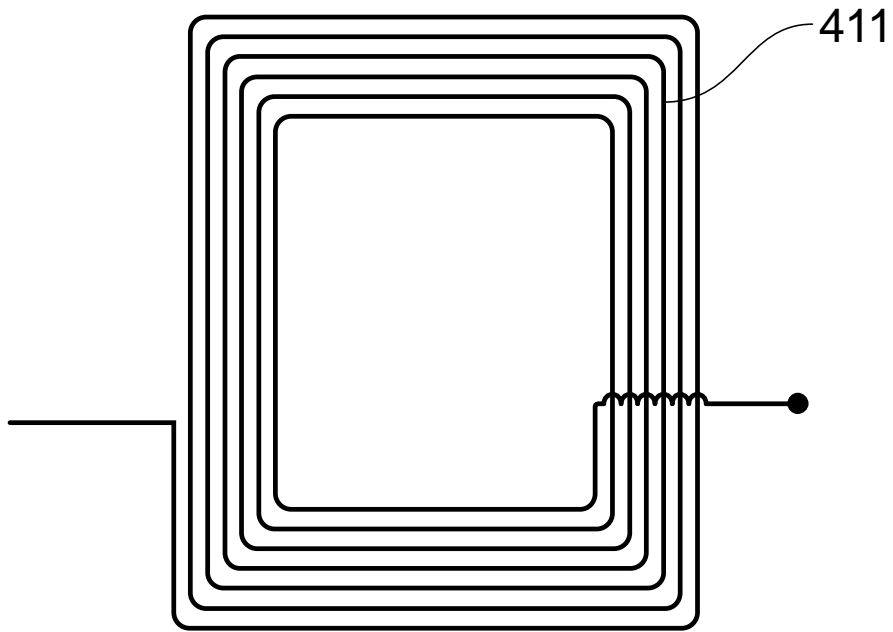

FIG. 1

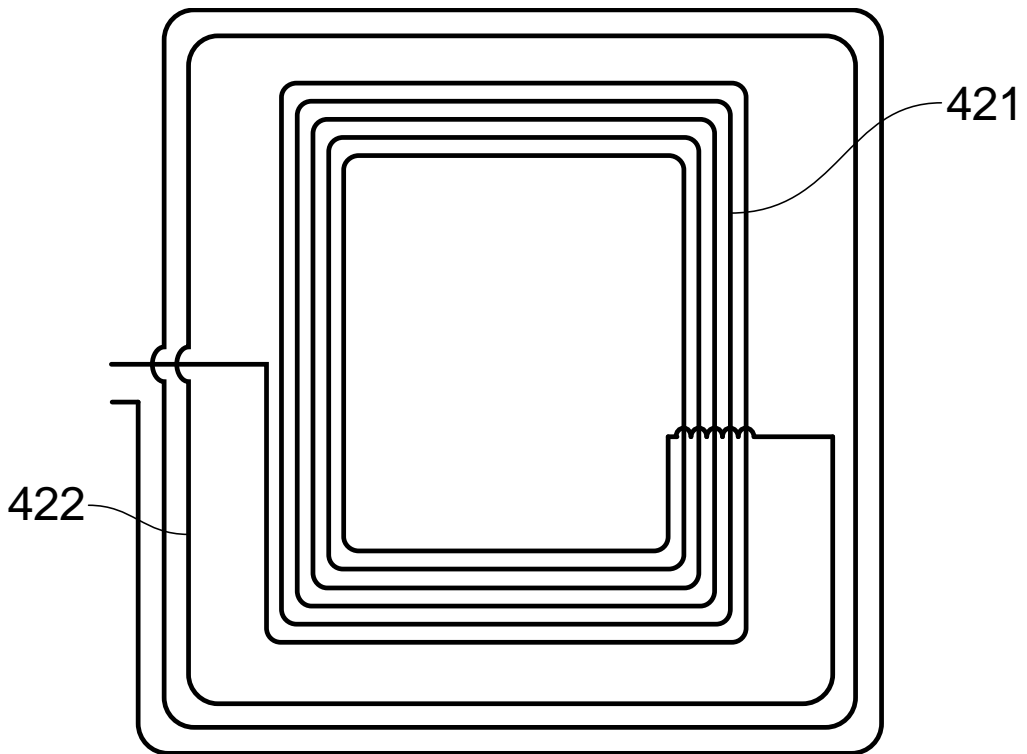

FIG. 2

Advertising brochure

Distributed with Lawn & Order, Journal for Xtreme Gardening,  
vol. 01/2020, 13 Dec. 2019

[1] The electrically powered ORBIT is a robot mower for professional lawn care. Designed to mow up to 10 hectares per day, it greatly reduces the size of the fleet needed to maintain a golf course. Although a robot mower is not a car we've put the latest technology from automotive manufacturers and other high-tech companies into our latest model.

[2] The ORBIT comes equipped with a system for resonant wireless charging licensed from a leading car manufacturer. Unsafe metal contacts in the charging dock are now a thing of the past. Corrosion or short circuits because of wet cut grass or rainwater are no longer a problem either.

[3] There's no risk of unwanted electromagnetic radiation interfering with smart home equipment of your clients: the wireless charging system uses reverse windings for active shielding which are embedded in a protective magnetic material consisting of TP.190 at 52% by weight and nanocrystalline FeCuSiB and amorphous CoFeNi at a ratio of 2:1.

[4] This composition has been designed specifically to withstand corrosion caused by wet conditions. Another safety feature is the fact that you don't have to switch the charging dock on or off. The charging dock contains a pressure sensor which activates the charging pads as soon as the ORBIT moves into the dock.

[5] To detect obstacles and dangerous objects, a sensing system (see the arrow in Fig. 1) mounted at the front of the ORBIT continuously monitors the robot's surroundings. The sensing system can be an ultrasound sensing system (USS) or a resonant sensing system (RSS).

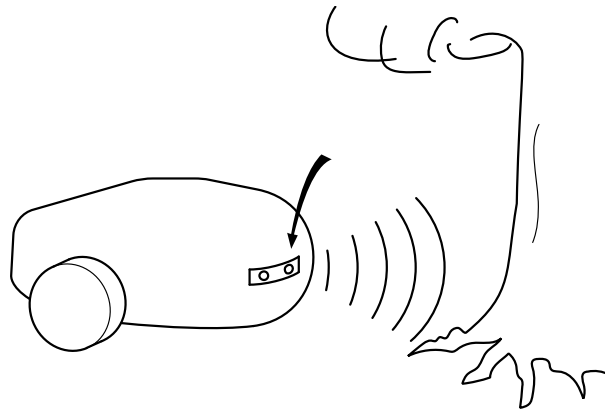

Fig. 1: ORBIT with sensing system (see arrow)

[6] The USS works by continuously emitting an ultrasound sensing field. If the sensing field is reflected by a sufficiently large obstacle, the reflected field affects a detection current in a detection transducer also mounted at the front of the robot. The obstacle creates changes in the detection current as the ORBIT approaches.

[7] Downstream of the sensing system (see Fig. 2) the detection current is continuously measured by a sampling circuit and forwarded as a signal to a microprocessor. This microprocessor is programmed to evaluate whether a detected change means that the robot is approaching an obstacle or not.

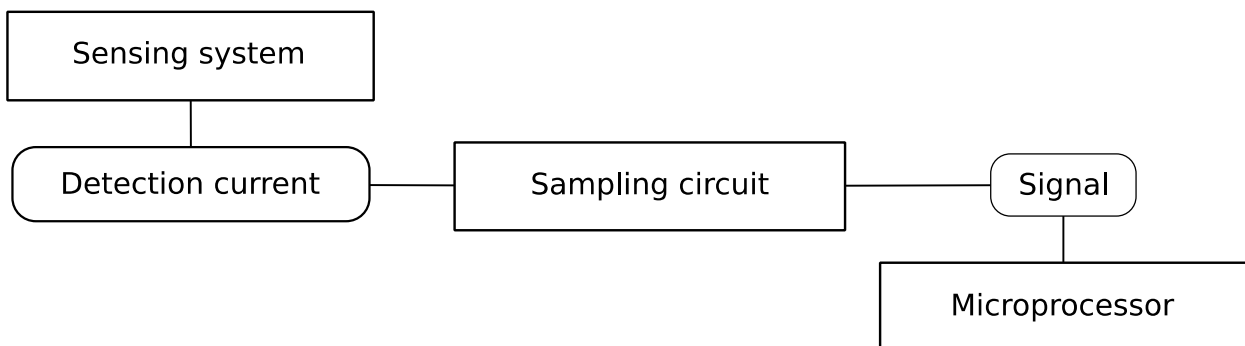

Fig. 2: Circuit diagram

[8] The RSS is an upgrade which can be retrofitted to replace the USS, for instance during routine maintenance. The circuit components downstream of the sensing system function independently of whether USS or RSS is used. No changes to the robot's body are required.

[9] The RSS works by continuously sending an excitation current into an excitation solenoid tuned to 500 kHz to generate a nearby electromagnetic sensing field. An obstacle such as a cat or a beer can left on the lawn affects the electromagnetic sensing field as the ORBIT approaches.

[10] A probing solenoid is mounted in proximity to the excitation solenoid and is also tuned to 500 kHz. The probing solenoid continuously picks up the sensing field and creates a detection current which reacts to any changes in the sensing field.

[11] Thus an obstacle affecting the sensing field leads to corresponding changes in the detection current as the ORBIT approaches.

[12] Resonant sensing has several advantages. Pets are reliably detected because a living body strongly distorts the sensing field. Resonant sensing also reliably detects metal objects, so it will protect your mower's blades. Once an obstacle is detected the microprocessor instructs the robot to turn and go in a different direction. The RSS operates at 500 kHz, while the coils in the charging pads have a layout so that they are tuned to the charging frequency of 85 kHz. This means there is no risk of harmful interference.

[13] When the microprocessor detects a low battery charge, it sends the ORBIT back to its charging station. If the charging pad is blocked by an obstacle (such as your cat), the sensing system emits a warning sound and/or light to alert you (and maybe scare your cat away).

Transcript of podcast downloaded 2024-03-14, 09:24:18

## E-Mobility – BBCee Radio9 with Walt Edge and Dan Shen

- [1] **Walt:** Hi everybody, this is our show on BBCee Radio9 about electric mobility, broadcast on 30 May 2020. Real radio about real cars for real people. As usual, the show will also be available on the Podcloud website in our podfeed.
- [2] **Dan:** Today's big story: an exclusive preview of model P, OS-corp's next big thing. I visited their headquarters this morning. Model P will be their first electric car to go fully wireless. Of course, it has the usual wireless data connection for software updates and receiving all kinds of data. But it will also feature exciting advances for wirelessly charging the battery.
- [3] To be more specific: Model P has a car charging pad with a double-O solenoid. Up to now this had only ever been seen in concept studies. Safety has also been improved thanks to automated charging.
- [4] **Walt:** Come on, what's new about that? OS-corp's model Q got automated charging in 2018 when it was last updated.
- [5] **Dan:** Hurm ... I don't remember that. Remind me what happened.
- [6] **Walt:** OK. So, OS-corp sold their model Q between 2015 and 2017. It was the first to be compatible with the then newly introduced standard RFC-7511-x. Model Q came with a plug-and-socket charging system but was already able to establish a wireless data link between the car's on-board computer and the charging terminal.
- [7] **Dan:** Ah yes, customers loved it because exchanging billing information suddenly became much, much easier. Plus, it was now possible to control the microprocessor in the charging terminal to start or stop charging with a single tap of the finger on the on-board computer's display.



- [8] **Walt:** That's one of the many functions of model Q's battery control system, which is software that runs on the on-board computer. It also decides, for instance, on values for the electric voltage and electric current during charging. In 2018 all owners received a software update which implemented charging based on the battery's temperature.
- [9] **Dan:** I think I'm beginning to remember now. Model Q has a heat sensor inside the battery which sends the temperature as a signal to the battery control system. In the original configuration the temperature value was forwarded to the on-board computer for display on the dashboard to let the driver decide if charging should begin or not. It's long been known that charging at low temperatures is not very efficient and might not even be safe.
- [10] **Walt:** The 2018 update enabled the battery control system to take over the decision-making. It checks if the temperature is in a range deemed acceptable for battery charging.
- [11] If it's not, the battery control system decides that charging shouldn't start or, if it's already begun, that it should be stopped. If the temperature becomes acceptable again, for instance because it's warm the next day, the battery control system allows charging to continue or may initiate it if it has not yet begun.
- [12] This automated decision-making can be disabled, but is very popular because it means users don't have to decide if they need to intervene.
- [13] **Dan:** One thing less to worry about, ha ha.  
Anyway, I see your point. However, model P as presented yesterday offers automated decision-making for a different reason. It's intended for when you realise something is in the charging area between the ground charging pad and the car charging pad which shouldn't be there.

- [14] **Walt:** Well, I wouldn't want that to be my cat. Has OS-corp come up with a high-tech solution?
- [15] **Dan:** I'd call it mid-tech. Model P is equipped with an infrared sensor which monitors the thermal signature in the charging area. The sensor's output current is sampled at the input of the on-board computer, meaning that the strength of the thermal signature is available as a signal which can be processed.
- [16] The on-board computer detects any changes which are strong enough to mean that your cat might have moved into the charging area. The on-board computer will then trigger a visual and sonic alert.
- [17] **Walt:** That might scare the cat away – but if it doesn't the poor thing will remain fully exposed to the strong electromagnetic charging field still present in the charging area.
- [18] **Dan:** No, no, that would be too dangerous. Model P's on-board computer can have all the power switches change from on to off or vice versa: the power switches connecting the car charging pad to the battery and also the power switches within the charging terminal which feeds electrical energy into the ground charging pad. This means the electromagnetic charging field can be switched off entirely, giving complete protection from inadvertent field exposure.
- [19] **Walt:** I see. Once you've made sure the charging area is free – one tap of the finger and charging begins again. But how well does an infrared sensor work in summer when the ambient temperature is already quite high? Also, what happens if a beer can rolls into the charging area?
- [20] **Dan:** You're right, an infrared sensor might miss these situations. I'm sure there's more to come with model P. Software updates are easier but OS-corp's engineers often also propose hardware upgrades as long as they don't require any changes to the car's body.

Screenshot downloaded and printed 2024-03-14, 07:42:18

<https://www.podcloud.com/BBC9/programmes/b07dx75g>



*E-Mobility is a show presented by Walt Edge (@waltedg) and Dan Shen (@danshen) and broadcast by BBCee Radio9 in London, UK. The producer is Ann Pear. Music by Kara Ent.*

### Comments posted

*User Max1111 on 2020-05-31: Great to hear that model P has wireless charging – but what about model Q? I have one and would really like to switch to wireless charging.*

*Reply from Walt on 2020-06-01: Upgrading from plug-socket technology to wireless charging would require extensive redesign – that’s not going to happen.*

*User Maurice2222 on 2023-08-08: Yesterday OS-corp’s erratic boss Norman Osbusk announced on GeWitter that model P will get an upgrade: price-dependent charging. Typical, always thinking about money.*

**(19) European Patent Office**

- (21) Application number: **20161803.9**  
(11) Publication number: **EP 3 631 538 A1**  
(45) Date of filing: **5 January 2020**  
(30) Priority: **15 January 2019 DE 101 6726 2192.3**  
(43) Date of publication: **29 July 2020**  
(51) Int. Cl.: **H01F27/28, B60L53/665, Y02T90/10**  
(71) Applicant: **Clarke & Ayrton Ltd.**  
(72) Inventor: **Wasita C. Atisaw, Lamesur E. Rusemal**

**(54) Charging method for solenoid with active shielding**

[1] Wireless charging pads for high energy transfer rates need preventive measures against unwanted electromagnetic fields.

[2] Active shielding may be used to reduce leakage fields so that a charging pad complies with regulations.

[3] Fig. 1 shows a solenoid 711 for a charging pad. According to the invention, the solenoid is supplemented with reverse windings 712 which are wound concentrically around the solenoid in the reverse winding direction compared to the solenoid.

[4] Active shielding enables high energy transfer rates while complying with regulations but energy transfer efficiency is slightly reduced. This reduced efficiency is acceptable at public charging points, where users want a short charging period. If a battery-powered car is being charged at home, the speed of charging is usually not an issue.

[5] According to the invention, the slightly reduced energy transfer efficiency is offset by performing wireless charging only when electricity prices are low.

[6] Price-dependent charging does not require additional infrastructure investments if the user already has a charging terminal adhering to the RFC-7511-x standard from 2017. Charging terminals adhering to RFC-7511-x have the advantage that they can be used both for plug-socket charging (a two-way cable is plugged into the charging terminal and a car) and for wireless charging (a cable for a compatible ground charging pad is plugged into the charging terminal).

[7] Such charging terminals contain a programmable microprocessor which is able to communicate wirelessly with the car's on-board computer. They also contain power switches which enable or disable the electrical connection to the electricity grid. Any skilled person in the field knows that for safety reasons any cable plugged into the charging terminal should be kept free from electrical tension unless the battery is being charged.

[8] Most importantly, such charging terminals also have mobile data connectivity which enables them to continuously receive signals indicating the price of electricity.

[9] If the price of electricity drops below a first value which can be set by the user, the microprocessor may trigger charging. If the price of electricity rises above a second value which can also be set by the user, the microprocessor may interrupt charging. The choice of the first and second values are decisions depending on the user's business interests.

[10] The microprocessor operates the power switches in the charging terminal accordingly, meaning that charging is prevented unless prices are low.

## Claims

1. Charging pad for wireless inductive charging in which the solenoid is supplemented with reverse windings which are wound concentrically around the solenoid with reverse polarity to the solenoid so that when a current passes through the solenoid, the same current will pass through the reverse windings.
2. Method of using a charging pad of claim 1, the method comprising performing wireless charging only when electricity prices are low.

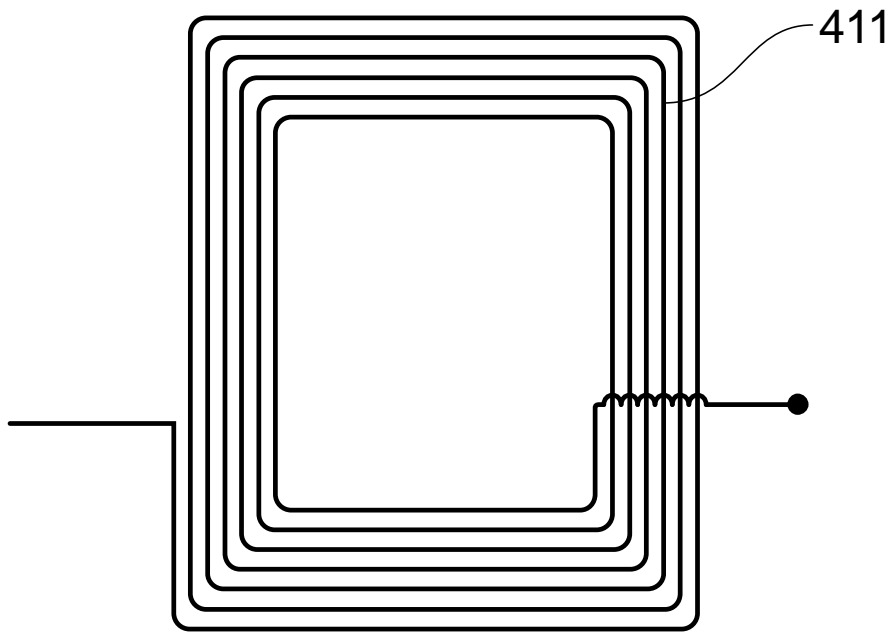

FIG. 1